

Bulletin 700-SH

- 100 A Max. Continuous Load (Output) Current with Appropriate Heat Sink
- 264V AC, 530V AC, or 660V AC Max. Load Voltage Options
- 3...32V DC, 4...32V DC, 80...130V AC, 200...260V AC, 20...280V AC/22...48V DC Control (Input) Voltage Options
- LED Indicator for Input/Logic ON/OFF Status Monitoring
- Protective Cover for Added Safety

Standards Compliance and Certifications

- UL 508
- CSA C22.2
- CE

Product Selection



	Input-to-Output Isolation Method	Zero Cross Function	LED Indicator	Output (Load) Max. Continuous Current and Rated Voltage Range*	Rated Input Control Voltage	Cat. No.*
	Optocoupler	Yes	Yes	10 A @ 42...265V AC	3...32V DC	700-SH10JZ24
				10 A @ 42...265V AC	80...130V AC	700-SH10JA12
				10 A @ 42...265V AC	200...260V AC	700-SH10JA22
				10 A @ 42...530V AC	4...32V DC	700-SH10HZ25 (Series B)
				25 A @ 42...530V AC	20...280V AC/22...48V DC	700-SH25HZ25(Series B)
				25 A @ 24...265V AC	3...32V DC	700-SH25GZ24
				25 A @ 24...265V AC	20...280V AC/22...48V DC	700-SH25GA24
				50 A @ 24...265V AC	3...32V DC	700-SH50GZ24

				50 A @ 24...265V AC	20...280V AC/22...48V DC	700-SH50GA24
				50 A @ 42...530V AC	4...32V DC	700-SH50HZ25
				25 A @ 42...660V AC	4...32V DC	700-SH25VZ25
				25 A @ 42...660V AC	20...280V AC/22...48V DC	700-SH25VA24
				50 A @ 42...660V AC	4...32V DC	700-SH50VZ25
				50 A @ 42...660V AC	20...280V AC/22...48V DC	700-SH50VA24
				75 A @ 42...530V AC	4...32V DC	700-SH75HZ25
				75 A @ 42...660V AC	4...32V DC	700-SH75VZ25
				75 A @ 42...530V AC	20...280V AC/22...48V DC	700-SH75HA24
				75 A @ 42...660V AC	20...280V AC/22...48V DC	700-SH75VA24
				100 A @ 42...530V AC	4...32V DC	700-SH100HZ25
				100 A @ 42...530V AC	20...280V AC/22...48V DC	700-SH100HA24
				100 A @ 42...660V AC	4...32V DC	700-SH100VZ25
				100 A @ 42...660V AC	20...280V AC/22...48V DC	700-SH100VA24
		Not Applicable	No	5 A @ 3...60V AC	3...32V DC	700-SH5FZ24
		Yes	Yes	25 A @ 90...280V AC	4...20 mA DC	700-SH25WA25
				50 A @ 90...280V AC	4...20 mA DC	700-SH50WA25

* All catalog numbers are Series A unless noted.

⊗ This type is also called Phase Angle 0 when used with heat sink.

Accessories

	Description	Pkg. Quantity	Cat. No.
	Heat Sink— Panel or DIN Rail Mount	1	700-SN10
Cat. No. 700-SN10			
	Heat Sink— Panel or DIN Rail Mount	1	700-SN20
Cat. No. 700-SN20			
	Heat Sink— Panel or DIN Rail Mount	1	700-SN30
Cat. No. 700-SN30			
	Heat Sink— Panel or DIN Rail Mount	1	700-SN50HC
Cat. No. 700-SN50HC			
	Heat Sink— Panel or DIN Rail Mount	1	700-SN50VHC

Cat. No. 700-SN50VHC			
	DIN (#3) symmetrical rail 35 mm x 7.5 mm x 1 m long	10	199-DR1
Cat. No. 199-DR1			

Specifications

Control/Input Ratings

Cat. No.	Operating Voltage	Input Current @ Max. Voltage	Voltage Level Pickup Voltage	Drop-Out Voltage
700-SH10J...	3...32V DC	12 mA	2.75V DC max.	1.2V DC min.
	80...130V AC	13 mA	70V AC max.	30V AC min. *
	200...280V AC	13 mA	190V AC max.	90V AC min.
700-SH__H...	4...32V DC	12 mA	4V DC max.	1V DC min.
	20...280V AC/22...48V DC	20 mA	18V AC/DC	6V AC/DC
700-SH__G...	3...32V DC	12 mA	2.5V DC	1.2V DC
	20...280V AC/22...48V DC	20 mA	-32V DC	6V AC/DC
700-SH__V...	4...32V DC	12 mA	3.5V DC	1.2V DC
	20...280V AC/22...48V DC	20 mA	18V AC/DC	6V AC/DC
700-SH__W...	Current Control	4...20 mA	—	—
700-SH__F...	3...32V DC	12 mA	3V DC max.	1.0V DC

* When specified heatsink is used.

Output Ratings

Cat. No.	Load Voltage Range	Applicable Load Current with Heat Sink* ‡
700-SH5FZ24	3...60V DC	0.001...5 A DC

700-SH10J...	42...265V AC	0.15...10 A
700-SH10H...	42...530V AC	0.15...10 A
700-SH25G...	24...265V AC	0.15...25 A
700-SH25H...	42...530V AC	0.15...25 A
700-SH25V...	42...660V AC	0.15...25 A
700-SH25W...	90...280V AC	0.15...25 A
700-SH50G...	24...265V AC	0.15...50 A
700-SH50H...	42...530V AC	0.15...50 A
700-SH50V...	42...660V AC	0.15...50 A
700-SH50W...	90...280V AC	0.15...50 A
700-SH75H...	42...530V AC	0.15...75 A
700-SH75V...	42...660V AC	0.15...75 A
700-SH100H...	42...530V AC	0.15...100 A
700-SH100V...	42...660V AC	0.15...100 A

★ When specified heat sink is used.

※ AC unless indicated.

Characteristics

Cat. No. **700-SH10, 25, 50 (not including 700-SH_ _W) 700-SH75, 100**

Pick-up Time	1/2 of load power source cycle time(DC input) 1 of load power source cycle time (AC input)
Drop-out Time	1/2 of load power source cycle time (DC input) 2 of load power source cycle time (AC input)
Output ON Voltage Drop	1.6V (RMS) max.
Output Leakage Current	<3 mArms 100 MΩ min (@ 500V DC)
Insulation Resistance	100 MΩ min. (at 500V DC)
Dielectric Strength	>4000 VACrms
Vibration Resistance	Malfunction: 10...55 Hz, 1.5 mm double amplitude
Shock Resistance	Malfunction: 1,000 m/s ²

Ambient Temperature	Operating: -20...70 °C with no icing or condensation	
	Storage: -40...100 °C with no icing or condensation	
Ambient Humidity	0...95% no condensing	
Standards Compliance*	UL508, CSA C22.2 (No. 0, No. 14), (EN60950), CE	
Weight	Approx. 60 g	Approx. 100 g

Characteristics

Cat. No. 700-SH_ _W

Pick-up Current	4.2 mA
Drop-out Current	4.1 mA
Voltage Drop	<10V DC @ 20 mA
Leakage Current	<3 mA
Insulation Voltage	<4000 Vrms
Vibration Resistance	Malfunction: 10...55 Hz, 1.5 mm double amplitude
Shock Resistance	Malfunction: 1,000 m/s ²
Ambient Temperature	Operating: -20...70 °C with no icing or condensation
Ambient Humidity	0...95% no condensing
Standards Compliance*	UL508, CSA C22.2 (No. 0, No. 14), (EN60950), CE
Weight	Approx. 60 g

Characteristics

Cat. No. 700-SH5FZ24

Pick-up voltage	<3V DC
Drop-out voltage	>1V DC
Activating Frequency	<100 Hz
Input Impedance	1k Ω
Response Time Pick-up @ Vin > 5V	<4000 μ S

Response Time Drop-out	<1 mS
On-state Voltage Drop @ Rated Current	<1.5V
Off-state Current Drop @ Rated Voltage	<1mA
Insulation Voltage	<1mA
Vibration Resistance	Malfunction: 10...55 Hz, 1.5 mm double amplitude
Shock Resistance	Malfunction: 1,000 m/s ²
Ambient Temperature	Operating: -20...70 °C with no icing or condensation
Ambient Humidity	0...95% no condensing
Standards Compliance*	UL508, CSA C22.2 (No. 0, No. 14), (EN60950), CE
Weight	Approx. 60 g

Surge Current vs. Ambient Temperature Characteristics

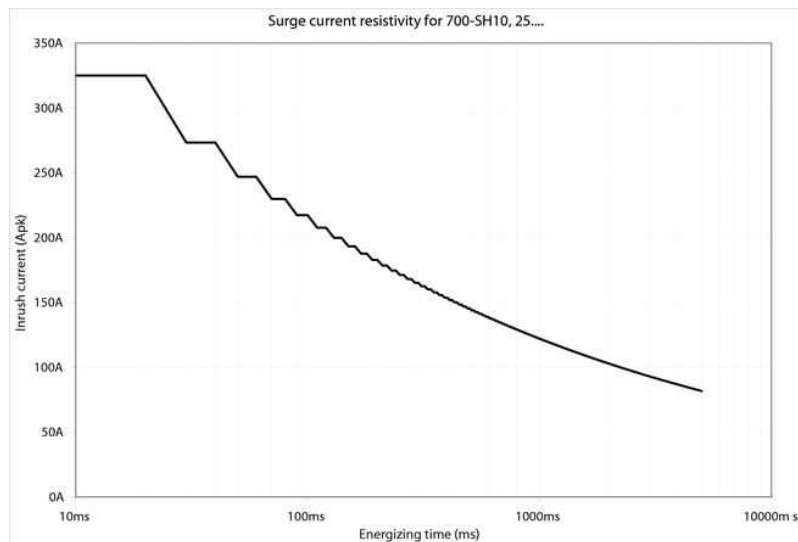

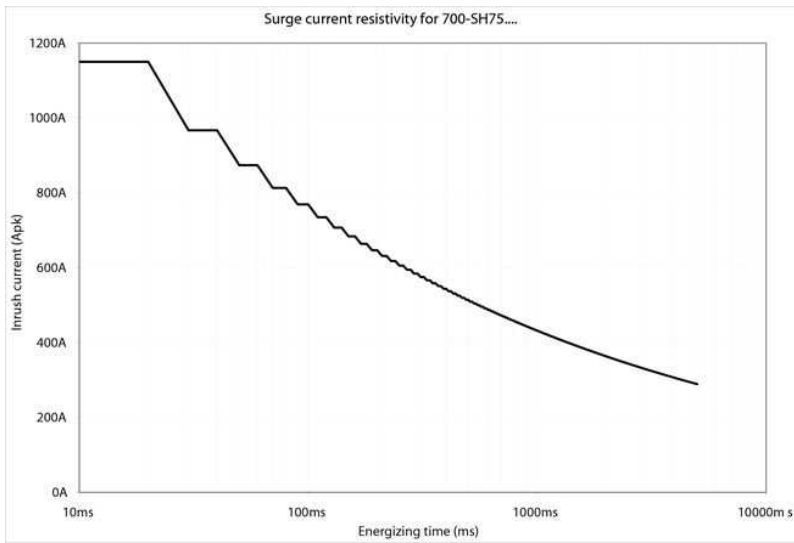
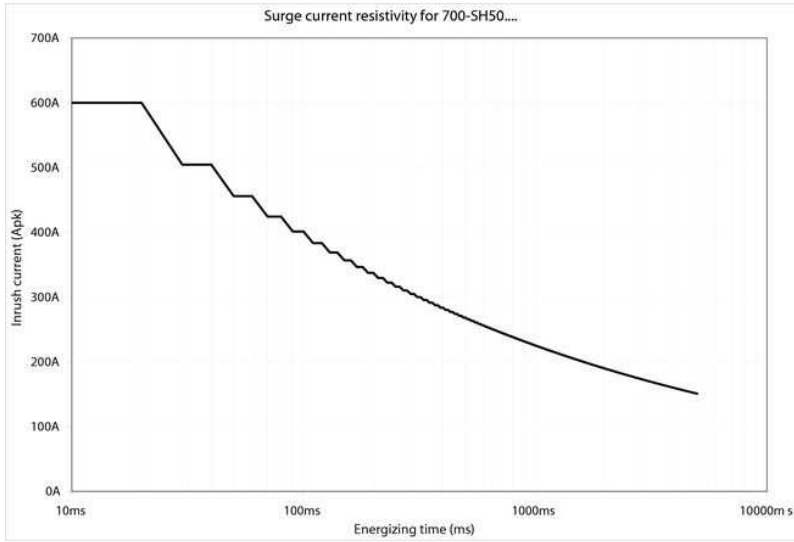

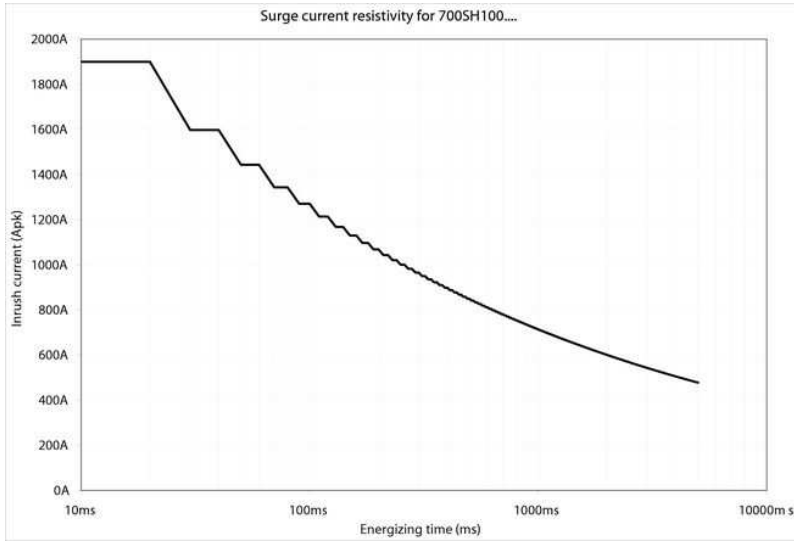

Load Current vs. Ambient Temperature Characteristics

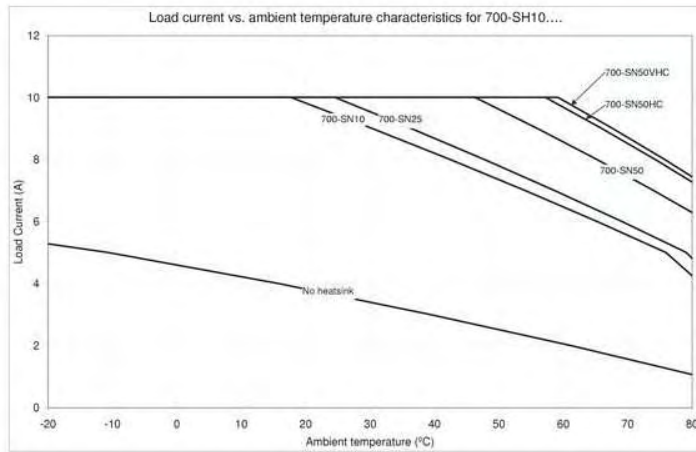

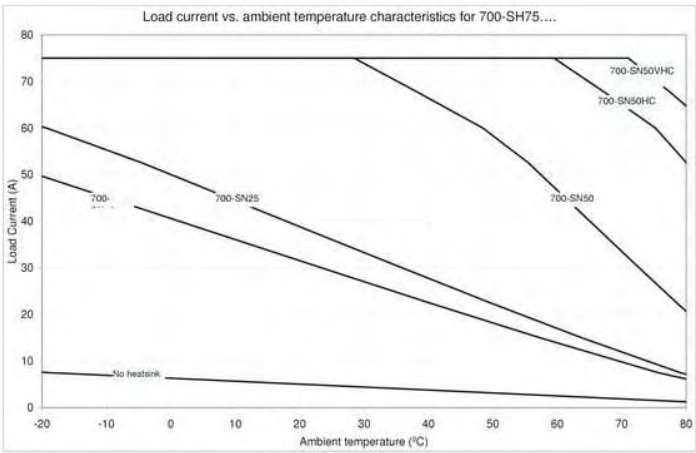
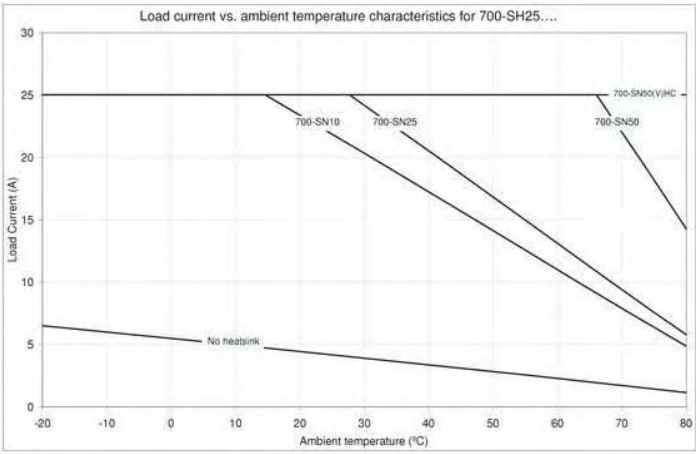

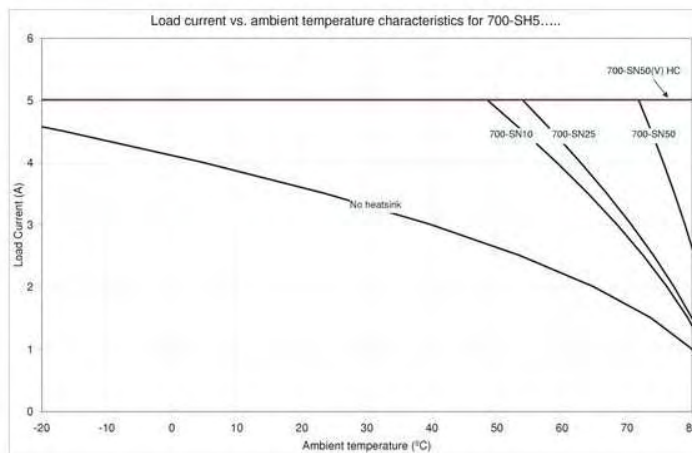
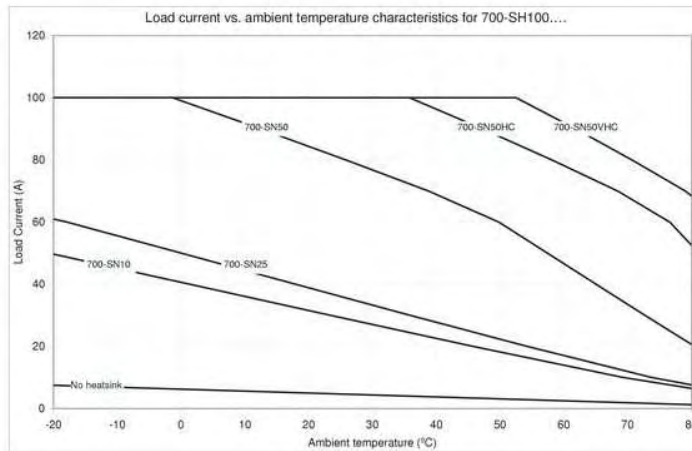

Approximate Dimensions

Mounting Considerations * ❄️ † § ♣️

All units are in mm's unless otherwise indicated. To convert to inches multiply by 0.0394.
 Dimensions are not intended for manufacturing purposes.

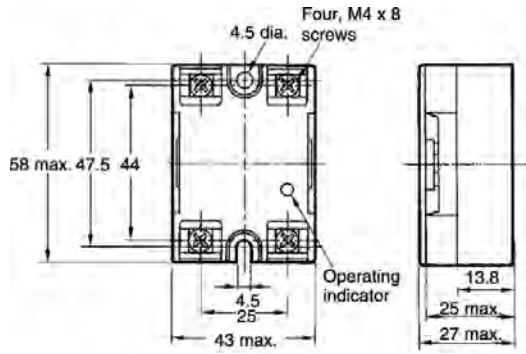

Cat. No. 700-SH05...

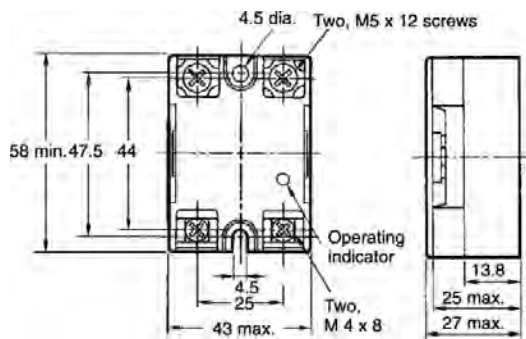
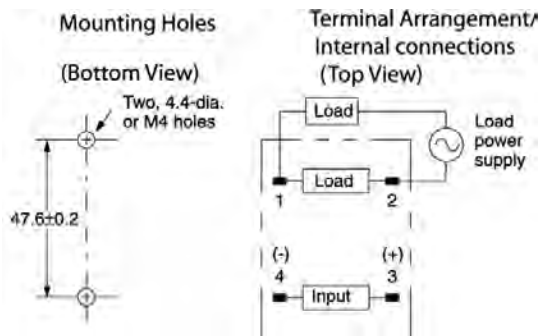

Cat. No. 700-SH40

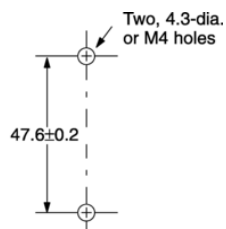

- * The proper mounting orientation of the heat sink is so the heat fins run perpendicular to the floor (vertical) to maximize ventilation flow.
- ※ If the fins do not run perpendicular to the floor, a 30% current derating is required.
- ‡ When attaching a heat sink to Bulletin 700-SH, apply a thin layer of heat conductive grease (approximately 0.002in. thick) on the heat sink to maximize heat transfer between the SSR and the heat sink. Recommended types: Silicon based, Dow Corning 340, Toshiba YG6240; Non-silicon based, AOS company type 53300 (Cat. No. 46801-010-01).
- § Tighten the SSR panel/heat sink mounting screws to a torque of 0.78...0.98 N•m (6.9...8.7 lb•in).
- ♣ Tighten the SSR terminal wiring screws as follows M4: 0.98...1.37 N•m (8.67...12.12 lb•in), M5: 1.57...2.35 Nm (13.89...20.8 lb•in).

Heat Sinks ➤ ⌘

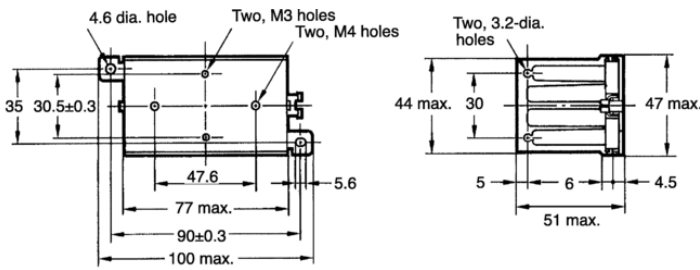

Cat. No. 700-S10

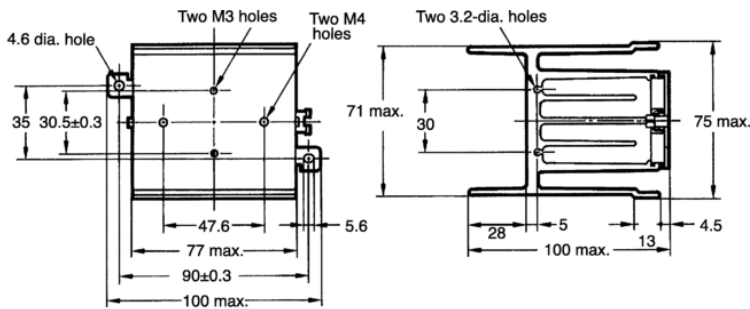
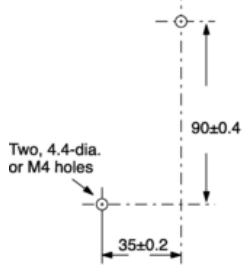

Cat. No. 700-S20

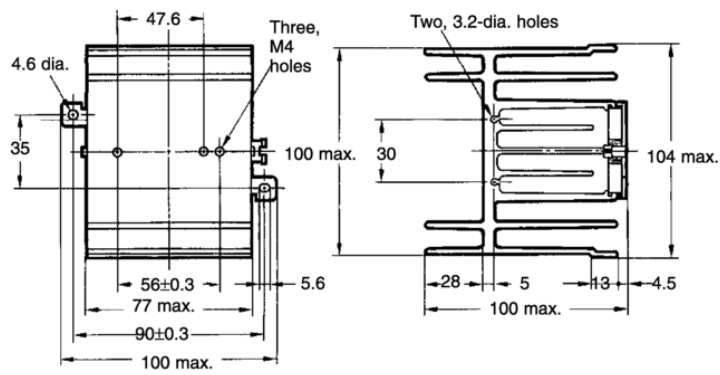
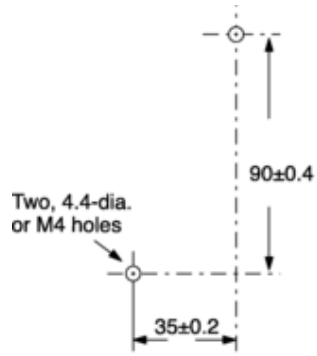

Cat. No. 700-S30

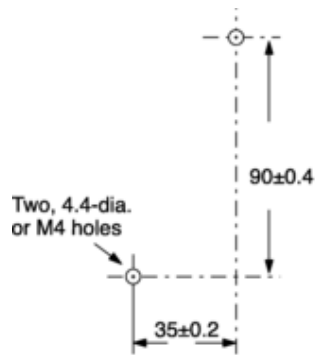

➤ Tighten the heat sink mounting screws (M4) to a torque of 0.98...1.37 N•m (8.67...12.12 lb•in).

⌘ Heat sink weight: cat. nos. 700-S10 = 200 g, 700-S20 = 400 g, 700-S30 = 560 g.

Basic Application Considerations

Load Connection

- For an AC load, use a power supply rated at 50 or 60 Hz. The maximum operating frequency is 10 Hz.
- The Bulletin 700-SH has a built-in varistor for surge/inrush protection of AC loads. If additional suppression is required, connect an external varistor across the load device terminals. Select a varistor which meets the load voltage condition outlined in the table below.

Load Voltage	Varistor Voltage	Varistor Surge Resistance
100...120V AC	240...270 V	1000 A min.
200...240V AC	440...470 V	
380...480V AC	820...1000 V	

Zero Cross Function

A SSR with a zero cross function operates when an AC load voltage reaches the zero point or its vicinity. This reduces clicking noises when the load is switched, and minimizes the influence of an inductive load, such as a lamp, heater, or motor, on the power supply because the inrush current of the load is reduced. This can also minimize the scale of the inrush current protection circuit.

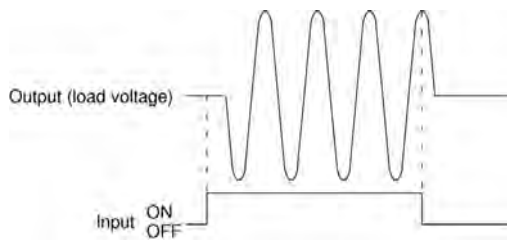

At a low applied voltage, such as 24V AC, the load current is not fully supplied. When the unit is switched ON, the voltage required to power the unit deprives the output signal of the necessary voltage level and thus creates loss time. The lower the load voltage is, the greater the loss time is. This condition, however, will not create any serious problems.

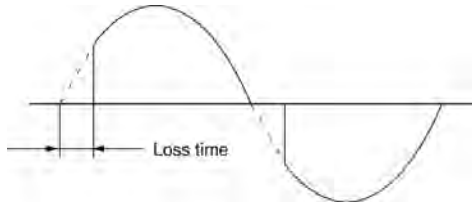

For a DC inductive load, a diode should be connected parallel to the load to absorb the counter electromotive force (OFF) of the load.

