

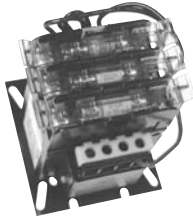



Transformers

				
Bulletin	1497	1497A	1497B	1497D
Type	Control Circuit Transformer	Machine Tool Transformer	Control Power Transformer	General Purpose Transformer
Features	<ul style="list-style-type: none"> • Single, dual, and multi-tap primary voltages • Single phase • EN 60-529 finger-safe protection • RoHS compliant • 50/60 Hz, 50 Hz, or 60 Hz 	<ul style="list-style-type: none"> • Dual/Multi-tap • RoHS compliant • Single phase • 50/60 Hz 	<ul style="list-style-type: none"> • Dual/Multi-tap • RoHS compliant • Single phase • 60 Hz only 	<ul style="list-style-type: none"> • Indoor/outdoor non-ventilated enclosure • Single phase • Exceeds requirements of the Uniform Building Code (UBC) and California Code Title 24 • Copper windings provided for all transformers rated 2 kVA and below • Aluminum windings provided for all transformers rated 2 kVA and above • NEMA Type 3R rated enclosures • 50/60 HZ or 60 Hz
Output Power	63...2000VA	50...3000VA	50...3000VA	0.05...25 kVA
Input Voltage/ Primary Voltage	208...600V 220...550 (50 Hz)	208...575V (50/60 Hz)	120...600V	208...600V
Output Voltage/ Secondary Voltage	24...120V 24...230V (50 Hz)	24...120V (50/60 Hz)	24...240V	120...240V
Insulation	63...2000VA — Class 130 °C (55...80 °C temp. rise)	50...150VA — Class 105 °C (55 °C temp. rise) 200...1500VA — Class 130 °C (80 °C temp. rise) 2000...3000VA — Class 180 °C (100 °C temp. rise)		Class 180 °C (115 °C temp. rise)
Certifications	cULus, CE, TÜV	cULus	cULus	UL, CSA
Standards	CSA C22.2 No. 66, EN 61558, UL 506	CSA C22.2 No. 66, UL 506	CSA C22.2 No. 66, UL 506	CSA C22.2 No. 47 — M90, UL 506
Product Selection	Page 8-36	Page 8-43	Page 8-49	Page 8-55

Control Circuit Transformers

Overview/Catalog Number Explanation



Cat. No. 1497-B-HXJX-3-N
Control Circuit Transformer, 3-pole
Fuse Block with Optional
Cat. No. 1491-R150 Fuse Cover



Cat. No. 1497-C-BASX-0-N
Control Circuit Transformer,
Non-Fused

Bulletin 1497 — Global Control Circuit Transformers

Bulletin 1497 Global Control Circuit Transformers are designed to reduce supply voltages to control circuits. The complete line of transformers is available with optional factory-installed or panel-mount primary and secondary fuse block. A dual primary and secondary fuse block is pre-wired and mounted on top of the transformer up to 500VA.

- 63...2000VA
- Single, dual, and multi-tap primary voltages
- Single phase
- EN 60-529 finger-safe protection
- Epoxy encapsulated
- RoHS compliant

Table of Contents

Product Selection 8-37
Approximate
Dimensions..... 8-41
Accessories..... 8-63

Standards Compliance

EN61558
C22.2 No. 66
UL 506

Certifications

cULus Listed (File No. E52057,
Guide No. XPTQ, XPTQ7)
CE

Catalog Number Explanation

Bulletin 1497 Multi-Tap Transformers

1497 - a - b - c - d

a

VA Rating	
Code	Description [VA]
A	63
B	80
C	130
D	200
E	250
F	350
G	500
H	750
J	800
K	1000
L	1600
M	2000

b

Primary and Secondary Voltage		
Code	Primary	Secondary
M1	240V, 208V	120V (60 Hz)
M2	240V, 208V	24V (60 Hz)
M3	240V, 208V	24V, 120V (60 Hz)
M4	415V, 400V, 380V	115X230V (50 Hz)
M5	415V, 400V, 380V	24V (50 Hz)

c

Fuse Block Options§	
Code	Block Options
0	0 Primary, 0 Secondary
1	0 Primary, 1 Secondary
2	2 Primary, 0 Secondary
3	2 Primary, 1 Secondary

d

Factory Installed Options	
Code	Description
N	No Fusing, No Cover

8

Bulletin 1497 Transformers

1497 - a - b - c - d

a

VA Rating	
Code	Description [VA]
A	63
B	80
C	130
D	200
E	250
F	350
G	500
H	750
J	800
K	1000
L	1600
M	2000

b

Primary and Secondary Voltage		
Code	Primary	Secondary
HX	208V (60 Hz)	—
AX	240V (60 Hz), 220V (50 Hz)	—
BA*	240X480V (60 Hz), 220X440V (50 Hz)	—
CX*	600V (60 Hz), 550V (50 Hz)	—
DX‡	—	120V (60 Hz)
JX	—	24V (60 Hz)
SX	—	120V (60 Hz), 110V (50Hz)
JK	—	24V (50 Hz), 26V (60 Hz)

c

Fuse Block Options§	
Code	Block Options
0	0 Primary, 0 Secondary
1	0 Primary, 1 Secondary
2	2 Primary, 0 Secondary
3	2 Primary, 1 Secondary

d

Factory Installed Options	
Code	Description
N	No Fusing, No Cover

* When the primary voltage code **BA** is selected and a 120V AC secondary is desired, the secondary voltage code **SX** should be selected.

* VA rating codes **G, H, or J** with primary voltage over 500V have only cULus approval.

‡ Not available for use with primary voltage code **BA**.

§ VA rating codes **H...M** are only available with no fuse block option (**0**).

Selecting a Control Circuit Transformer

For proper transformer selection, three characteristics of the load circuit must be determined in addition to the minimum voltage required to operate the circuit. These are total steady-state (sealed) VA, total inrush VA, and inrush load power factor.

- Total steady-state (sealed) VA is the volt-amperes that the transformer must deliver to the load circuit for an extended period of time — the amount of current required to hold the contact in the circuit.
- Total inrush VA is the volt amperes that the transformer must deliver upon initial energization of the control circuit. Energization of electromagnetic devices takes 30...50 milliseconds. During this inrush period, the electromagnetic control devices draw many times normal current — 3...10 times normal is typical.
- Inrush load power factor is difficult to determine without detailed vector analysis of all the load components. Such an analysis is generally not feasible. Therefore, a safe assumption is 40% power factor.

Selection Process

1. Determine the total inrush VA of the control circuits from the table below. Do not neglect the current requirements of indicating lights and other devices that do not have an inrush VA but are re-energized at the same time as the other components in the circuit. Their total VA should be added to the total inrush VA.
2. Refer to the table below, *Regulation Data — Inrush VA*. If the supply circuit voltage (Step 1) is reasonably stable and fluctuates not more than $\pm 5\%$, refer to the 90% secondary voltage column. If it fluctuates as much as $\pm 10\%$, refer to the 95% secondary voltage column. Go down the column selected until at the inrush VA closest to, but not less than, the inrush VA of the control circuit.
3. Read to the far left side of the chart. The transformer's continuous nominal VA rating is now selected. The secondary voltage that will be delivered under inrush conditions will be either 85%, 90%, or 95% of the rated secondary voltage, depending on the column selected from the table below, *Regulation Data — Inrush VA*. The total sealed VA of the control circuit must not exceed the nominal VA rating of the transformer selected from the table below, *Typical Magnetic Motor Starter and Contactor Data 60 Hz, 120 Volt, 3-Pole*.
4. Refer to the specification tables on the following pages to select a transformer according to the required continuous nominal VA, and primary and secondary voltage combinations.

Regulation Data — Inrush VA

Inrush VA at 40% Power Factor				Power Factor Adjustments	
Nominal VA Rating	85%	90%	95%	Power Factor	Multiply By
63	347	289	216	100%	0.64
80	338	290	229	90%	0.67
130	907	745	541	80%	0.71
200	1267	1039	754	70%	0.78
250	1394	1116	781	60%	0.82
350	2870	2298	1584	50%	0.91
500	3786	3013	2065	40%	1.00
750	7360	5763	3786	30%	1.11
800	7360	5763	3786	20%	1.29
1000	8837	6785	4329	10%	1.50
1600	14921	11328	7070	—	—
2000	20500	14850	9100	—	—

Typical Magnetic Motor Starter and Contactor Data 60 Hz, 120 Volt, 3-Pole

Contactor	NEMA Size						
	0	1	2	3	4	5	
Bulletin 500	192	192	240	660	1225	1490	VA Inrush
	29	29	29	45	69	96	VA Sealed

Bulletin 1497
Control Circuit Transformers
 Product Selection, Continued

Note: Refer to page 8-37 for information on how to select a control circuit transformer.

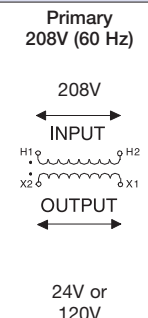
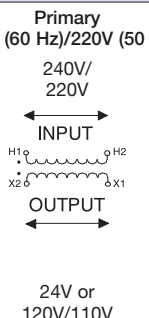
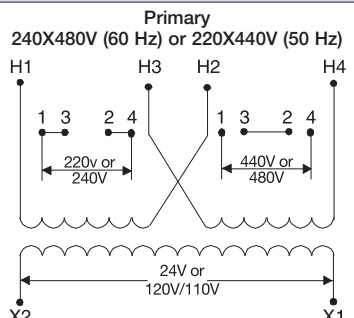
Continuous VA	Cat. Nos.					
	Primary 208V (60 Hz)		Primary 240V (60 Hz)/220V (50 Hz)		Primary 240X480V (60 Hz) or 220X440V (50 Hz)	
						
Secondary 24V (60 Hz)	Secondary 120V (60 Hz)	Secondary 26V (60 Hz)/24V (50 Hz)	Secondary 120V (60 Hz)/110V (50 Hz)	Secondary 26V (60 Hz) or 24V (50 Hz)	Secondary 120V (60 Hz) or 110V (50 Hz)	
63	1497-A-HXJX-0-N	1497-A-HXDX-0-N	1497-A-AXJK-0-N	1497-A-AXSX-0-N	1497-A-BAJK-0-N	1497-A-BASX-0-N
80	1497-B-HXJX-0-N	1497-B-HXDX-0-N	1497-B-AXJK-0-N	1497-B-AXSX-0-N	1497-B-BAJK-0-N	1497-B-BASX-0-N
130	1497-C-HXJX-0-N	1497-C-HXDX-0-N	1497-C-AXJK-0-N	1497-C-AXSX-0-N	1497-C-BAJK-0-N	1497-C-BASX-0-N
200	1497-D-HXJX-0-N	1497-D-HXDX-0-N	1497-D-AXJK-0-N	1497-D-AXSX-0-N	1497-D-BAJK-0-N	1497-D-BASX-0-N
250	1497-E-HXJX-0-N	1497-E-HXDX-0-N	1497-E-AXJK-0-N	1497-E-AXSX-0-N	1497-E-BAJK-0-N	1497-E-BASX-0-N
350	1497-F-HXJX-0-N	1497-F-HXDX-0-N	1497-F-AXJK-0-N	1497-F-AXSX-0-N	1497-F-BAJK-0-N	1497-F-BASX-0-N
500	1497-G-HXJX-0-N	1497-G-HXDX-0-N	1497-G-AXJK-0-N	1497-G-AXSX-0-N	1497-G-BAJK-0-N	1497-G-BASX-0-N
750	1497-H-HXJX-0-N	1497-H-HXDX-0-N	1497-H-AXJK-0-N	1497-H-AXSX-0-N	1497-H-BAJK-0-N	1497-H-BASX-0-N
800	1497-J-HXJX-0-N	1497-J-HXDX-0-N	1497-J-AXJK-0-N	1497-J-AXSX-0-N	1497-J-BAJK-0-N	1497-J-BASX-0-N
1000	1497-K-HXJX-0-N	1497-K-HXDX-0-N	1497-K-AXJK-0-N	1497-K-AXSX-0-N	1497-K-BAJK-0-N	1497-K-BASX-0-N
1600	—	1497-L-HXDX-0-N	—	1497-L-AXSX-0-N	—	1497-L-BASX-0-N
2000	—	1497-M-HXDX-0-N	—	1497-M-AXSX-0-N	—	1497-M-BASX-0-N
With 2-Pole Primary and 1-Pole Secondary Top-Mounted Fuse Block * — Fuses Not Included						
63	1497-A-HXJX-3-N	1497-A-HXDX-3-N	1497-A-AXJK-3-N	1497-A-AXSX-3-N	1497-A-BAJK-3-N	1497-A-BASX-3-N
80	1497-B-HXJX-3-N	1497-B-HXDX-3-N	1497-B-AXJK-3-N	1497-B-AXSX-3-N	1497-B-BAJK-3-N	1497-B-BASX-3-N
130	1497-C-HXJX-3-N	1497-C-HXDX-3-N	1497-C-AXJK-3-N	1497-C-AXSX-3-N	1497-C-BAJK-3-N	1497-C-BASX-3-N
200	1497-D-HXJX-3-N	1497-D-HXDX-3-N	1497-D-AXJK-3-N	1497-D-AXSX-3-N	1497-D-BAJK-3-N	1497-D-BASX-3-N
250	1497-E-HXJX-3-N	1497-E-HXDX-3-N	1497-E-AXJK-3-N	1497-E-AXSX-3-N	1497-E-BAJK-3-N	1497-E-BASX-3-N
350	1497-F-HXJX-3-N	1497-F-HXDX-3-N	1497-F-AXJK-3-N	1497-F-AXSX-3-N	1497-F-BAJK-3-N	1497-F-BASX-3-N
500	1497-G-HXJX-3-N	1497-G-HXDX-3-N	1497-G-AXJK-3-N	1497-G-AXSX-3-N	1497-G-BAJK-3-N	1497-G-BASX-3-N

* Top-mounted fuse blocks are not available for transformers 750VA and higher.

Note: Refer to page 8-37 for information on how to select a control circuit transformer.

Continuous VA	Cat. Nos.		
	Secondary 26V (60 Hz)/24V (50 Hz)	Secondary 120V (60 Hz)/110V (50 Hz)	Secondary 115V/230V (50 Hz)
	<div style="display: flex; justify-content: space-around;"> <div style="text-align: center;"> <p>Primary*</p> <p>600V (60 Hz)/550V (50 Hz)</p> <p>550V 600V</p> <p>← INPUT →</p> <p>OUTPUT</p> <p>24V or 120V/110V</p> </div> <div style="text-align: center;"> <p>Primary</p> <p>380V, 400V, 415V (50 Hz)</p> </div> </div>		
63	1497-A-CXJK-0-N	1497-A-CXSX-0-N	1497-A-M4-0-N
80	1497-B-CXJK-0-N	1497-B-CXSX-0-N	1497-B-M4-0-N
130	1497-C-CXJK-0-N	1497-C-CXSX-0-N	1497-C-M4-0-N
200	1497-D-CXJK-0-N	1497-D-CXSX-0-N	1497-D-M4-0-N
250	1497-E-CXJK-0-N	1497-E-CXSX-0-N	1497-E-M4-0-N
350	1497-F-CXJK-0-N	1497-F-CXSX-0-N	1497-F-M4-0-N
500	1497-G-CXJK-0-N	1497-G-CXSX-0-N	1497-G-M4-0-N
750	1497-H-CXJK-0-N	1497-H-CXSX-0-N	1497-H-M4-0-N
800	1497-J-CXJK-0-N	1497-J-CXSX-0-N	1497-J-M4-0-N
1000	1497-K-CXJK-0-N	1497-K-CXSX-0-N	1497-K-M4-0-N
1600	—	1497-L-CXSX-0-N	1497-L-M4-0-N
2000	—	1497-M-CXSX-0-N	1497-M-M4-0-N
With 2-Pole Primary and 1-Pole Secondary Top-Mounted Fuse Block * — Fuses Not Included			
63	1497-A-CXJK-3-N	1497-A-CXSX-3-N	1497-A-M4-3-N
80	1497-B-CXJK-3-N	1497-B-CXSX-3-N	1497-B-M4-3-N
130	1497-C-CXJK-3-N	1497-C-CXSX-3-N	1497-C-M4-3-N
200	1497-D-CXJK-3-N	1497-D-CXSX-3-N	1497-D-M4-3-N
250	1497-E-CXJK-3-N	1497-E-CXSX-3-N	1497-E-M4-3-N
350	1497-F-CXJK-3-N	1497-F-CXSX-3-N	1497-F-M4-3-N
500	1497-G-CXJK-3-N	1497-G-CXSX-3-N	1497-G-M4-3-N

* Transformers 500...800VA with 500V primary do not carry the CE mark.
 * Top-mounted fuse blocks are not available for transformers 750VA and higher.

Control Circuit Transformers

Product Selection, Continued

Fuse Sizing Charts

Important: Select the fuse to protect the control circuit conductors in accordance with the National Electrical Code.

Primary Fuse Sizing Chart (When Only Primary Protection is Used)

Maximum Amp Rating for Current Limiting Fuses Based on Transformer Primary Voltage and the National Electrical Code

VA	208V	220V	240V	277V	347V	380V	400V	415V	440V	480V	500V	550V	600V	690V
63	0.75	0.75	0.75	0.5	0.5	0.4	0.4	0.4	0.4	0.25	0.25	0.25	0.25	0.25
80	1	1	1	0.75	0.5	0.5	0.5	0.5	0.5	0.5	0.4	0.4	0.4	0.25
130	1.5	1.5	1.5	1.25	1	1	0.75	0.75	0.75	0.75	0.75	0.5	0.5	0.5
200	2.5	2.5	2.5	2	1.5	1.5	1.5	1.25	1.25	1.25	1	1	1	0.75
250	3	3	3	2.5	2	1.5	1.5	1.5	1.5	1.5	1.5	1.25	1.25	1
350	5	4	4	3	3	2.5	2.5	2.5	2	2	2	1.5	1.5	1.5
500	4	3	3	5	4	3	3	3	3	3	3	2.5	2.5	2
750	6	5	5	4	3	5	5	5	5	4	4	4	3	3
800	6	6	5	4	3	3	3	5	5	5	4	4	4	3
1000	8	7	6	6	4	4	4	4	3	3	3	5	5	4
1600	12	12	11	9	7	7	6	6	6	5	5	4	4	3
2000	12	11	13	12	9	8	8	8	7	6	6	6	5	4

Primary Fuse Sizing Chart (When Primary and Secondary Protection is Used)

Maximum Amp Rating for Current Limiting Fuses Based on Transformer Primary Voltage and the National Electrical Code

VA	208V	220V	240V	277V	347V	380V	400V	415V	440V	480V	500V	550V	600V	690V
63	0.75	0.75	0.5	0.5	0.4	0.4	0.4	0.4	0.3	0.3	0.3	0.25	0.25	0.25
80	1.5	1.5	1.5	1	1	1	1	0.75	0.75	0.75	0.75	0.5	0.5	0.5
130	3	2.5	2.5	2	1.5	1.5	1.5	1.5	1.25	1.25	1.25	1	1	0.75
200	4	4	4	3	2.5	2.5	2.5	2	2	2	2	1.5	1.5	1
250	6	5	5	4	3	3	3	3	2.5	2.5	2.5	2	2	1.5
350	8	7	7	6	5	4	4	4	3	3	3	3	2.5	2.5
500	6	5	5	9	7	6	6	6	5	5	5	4	4	3
750	9	8	7	6	5	9	9	9	8	7	7	6	6	5
800	9	9	8	7	5	5	5	8	8	8	8	7	6	5
1000	12	10	10	9	7	6	6	6	5	5	5	8	8	7
1600	15	15	15	12	11	10	10	9	9	8	8	7	6	5
2000	20	20	20	18	14	12	12	12	10	10	10	9	8	7

8

Secondary Fuse Sizing Chart

Maximum Amp Rating for Current Limiting Fuses Based on the National Electrical Code

VA	24V	110V	115V	120V	230V
63	4	0.75	0.75	0.75	0.4
80	5	1	1	1	0.5
130	9	1.8	1.8	1.8	0.9
200	13	2.5	2.5	2.5	1.25
250	15	3.2	3.2	3.2	1.5
350	20	4.5	4.5	4.5	2.5
500	30	6.25	6.25	6.25	3
750	45	9	9	9	4.5
800	45	9	9	9	4.5
1000	60	12	12	12	6
1600	100	20	20	20	10
2000	—	25	25	25	12

Control Circuit Transformers

Approximate Dimensions

Dimensions are shown in inches (millimeters). Dimensions are not intended to be used for manufacturing purposes.

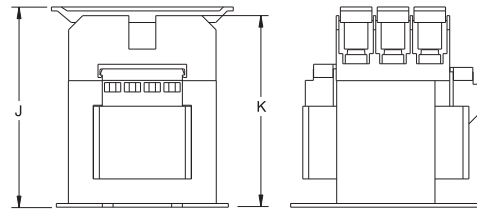
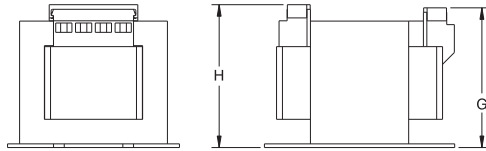
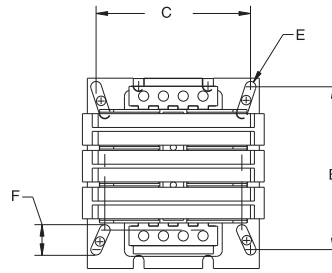
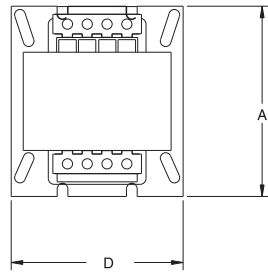

Transformer without Fusing

Transformer with Fuse Holder and Covers

VA	A	B	C	D	E	F	G	H	J	K	Approximate Shipping Wt. — lb (kg)	
											Without Top-Mounted Fuse Block	2-Pole Primary and 1-Pole Secondary Top-Mounted Fuse Block
63	3-7/8 (98.00)	3-1/4 (82.55)	3-1/8 (79.38)	3-1/2 (88.90)	7/32 (5.54)	22/32 (18.29)	2-27/32 (72.39)	2-3/8 (73.91)	4-5/64 (103.51)	3-57/64 (99.01)	4-1/2 (2.04)	4-4/5 (2.18)
80	3-7/8 (98.00)	3-1/4 (82.55)	3-1/8 (79.38)	3-1/2 (88.90)	7/32 (5.54)	22/32 (18.29)	2-27/32 (72.39)	2-3/8 (73.91)	4-5/64 (103.51)	3-57/64 (99.01)	4-1/2 (2.04)	4-4/5 (2.18)
130	3-7/8 (98.00)	3-1/4 (82.55)	3-1/8 (79.38)	3-1/2 (88.90)	7/32 (5.54)	22/32 (18.29)	3-3/8 (85.60)	3-13/32 (86.61)	4-45/64 (119.5)	4-35/64 (115.44)	6-7/10 (3.04)	7-3/20 (3.24)

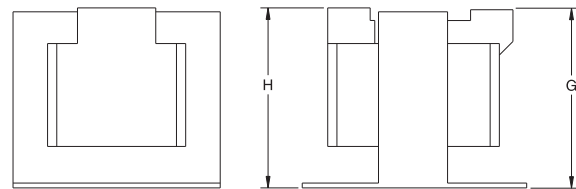
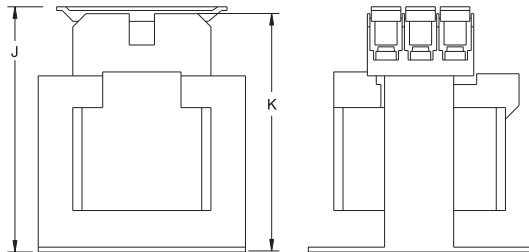
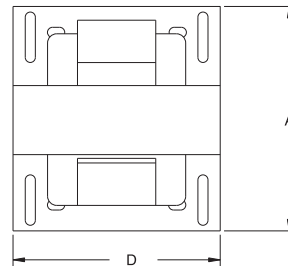
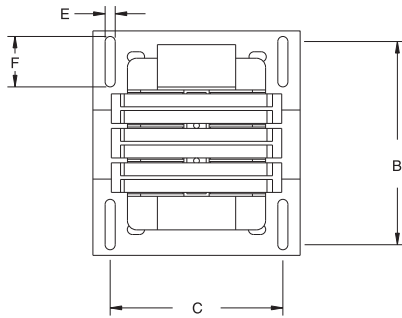

Transformer with Fuse Holder and Covers

Transformer without Fusing

VA	A	B	C	D	E	F	G	H	J	K	Approximate Shipping Wt. — lb (kg)	
											Without Top-Mounted Fuse Block	2-Pole Primary and 1-Pole Secondary Top-Mounted Fuse Block
200	4-7/8 (123.95)	4-7/16 (112.78)	3-3/4 (95.25)	4-1/2 (114.30)	7/32 (5.59)	1-1/8 (28.70)	3-3/8 (85.60)	3-29/32 (86.61)	5-21/64 (135.26)	5-11/64 (131.44)	8-2/5 (3.81)	8-7/10 (3.95)
250	4-7/8 (123.95)	4-7/16 (108.20)	3-3/4 (95.25)	4-1/2 (114.30)	7/32 (5.59)	1-1/8 (28.70)	3-7/8 (98.30)	3-29/32 (98.30)	5-21/64 (135.26)	5-11/64 (131.44)	10-2/5 (4.72)	10-4/5 (4.90)
350	4-7/8 (123.95)	4-7/16 (108.20)	3-3/4 (95.25)	4-1/2 (114.30)	7/32 (5.59)	1-1/8 (28.70)	3-7/8 (98.30)	3-29/32 (98.30)	5-21/64 (135.26)	5-11/64 (131.44)	13-2/5 (6.08)	13-4/5 (6.26)

Control Circuit Transformers

Approximate Dimensions, Continued

Dimensions are shown in inches (millimeters). Dimensions are not intended to be used for manufacturing purposes.

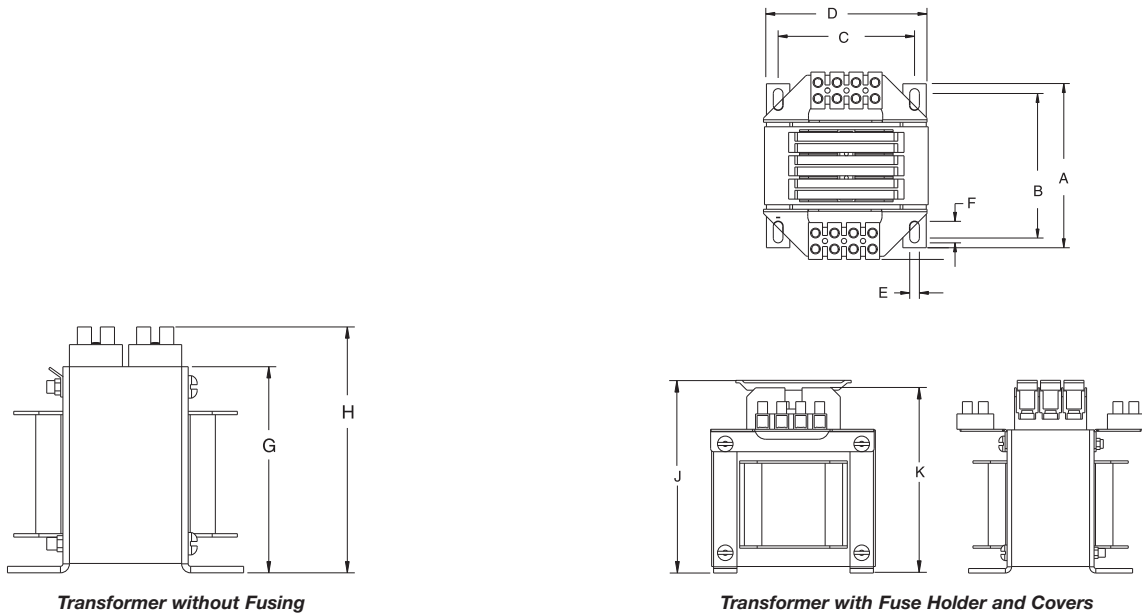

Transformer without Fusing

Transformer with Fuse Holder and Covers

VA	A	B	C	D	E	F	G	H	J	K	Approximate Shipping Wt. — lb (kg)	
											Without Top-Mounted Fuse Block	2-Pole Primary and 1-Pole Secondary Top-Mounted Fuse Block
500	5-1/4 (133.35)	4-33/64 (114.81)	4-3/8 (111.25)	5-1/4 (133.35)	5/16 (7.87)	45/64 (18.03)	4-17/32 (114.81)	5-1/2 (139.70)	6-3/16 (156.97)	5-15/16 (150.62)	17-3/5 (7.98)	17-19/20 (8.14)

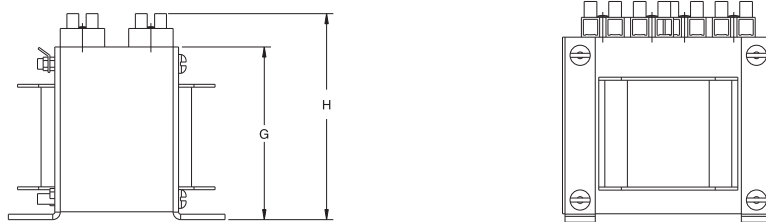
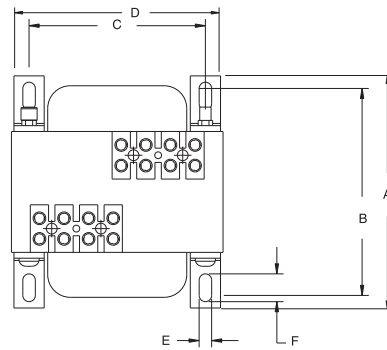

Transformer without Fusing

VA	A	B	C	D	E	F	G	H	Approximate Shipping Wt. — lb (kg)
									Without Top-Mounted Fuse Block
750	5-3/4 (146.05)	5 (127.51)	4-3/8 (111.25)	5-1/4 (133.35)	5/16 (7.87)	45/64 (18.03)	4-9/16 (114.81)	5-19/32 (137.41)	21-1/2 (9.75)
800	5-3/4 (146.05)	5 (127.51)	4-3/8 (111.25)	5-1/4 (133.35)	5/16 (7.87)	45/64 (18.03)	4-9/16 (114.81)	5-19/32 (137.41)	21-1/2 (9.75)
1000	6-3/8 (161.92)	5-3/8 (136.53)	5-5/16 (134.94)	6-3/8 (161.92)	5/16 (7.87)	45/64 (18.03)	5-33/64 (140.21)	6-1/2 (162.56)	37-1/5 (16.87)
1600	8-1/2 (215.90)	7-1/4 (184.15)	5-3/4 (143.76)	6-3/4 (171.45)	7/16 (10.92)	45/64 (18.03)	5-3/4 (146.05)	7-1/16 (168.66)	50-4/5 (23.04)
2000	9-1/2 (241.30)	8-1/4 (209.55)	5-3/4 (143.76)	6-3/4 (171.45)	7/16 (10.92)	45/64 (18.03)	5-11/64 (149.86)	7-1/16 (172.47)	61 (27.67)

Machine Tool Transformers

Overview/Catalog Number Explanation



Bulletin 1497A — Machine Tool Transformers

Bulletin 1497A Machine Tool Transformers are designed to reduce supply voltages to control circuits. The complete line of transformers is available with optional factory-installed or panel-mount primary and secondary fuse block/clip.

- 50...3000VA (50/60 Hz)
- RoHS compliant
- Single phase
- Epoxy encapsulated

Table of Contents

Product Selection 8-44
 Approximate Dimensions..... 8-47
 Accessories..... 8-63

Standards Compliance

C22.2 No. 66
 UL 506

Certifications

cULus Listed (File No. E52057, Guide No. XPTQ, XPTQ7)

Catalog Number Explanation

Bulletin 1497A Machine Tool Transformers

1497A – A1 – M6 – 0 – N
a *b* *c* *d*

VA Rating	
Code	Description [VA]
A1	50
A2	75
A3	100
A4	150
A5	200
A6	250
A7	300
A8	350
A9	500
A10	750
A11	1000
A12	1500
A13	2000
A14	3000

Primary and Secondary Voltage		
Code	Primary	Secondary
M6	220X440V, 230X460V, 240X480V	110, 115, 120V (50/60 Hz)
M7	230/460/575V	115/95V (50/60 Hz)
M8	208/277/380V	115/95V (50/60 Hz)
M18	208/230/480V (50/60 Hz)	120/24V (50/60 Hz)
M19	240X480V (50/60 Hz)	48V (50/60 Hz)

Fuse Block Options*	
Code	Block Options
0	0 Primary, 0 Secondary
1	0 Primary, 1 Secondary
3	2 Primary, 1 Secondary

Factory Installed Options	
Code	Description
N	No Taps

Note: For complete list of valid transformer configurations, see page 8-44.

* Transformers rated 350VA and below use secondary fuse clips. Transformers rated 500VA and above use secondary fuse blocks.

Machine Tool Transformers

Product Selection

Selecting a Machine Tool Transformer

For proper transformer selection, three characteristics of the load circuit must be determined in addition to the minimum voltage required to operate the circuit. These are total steady-state (sealed) VA, total inrush VA, and inrush load power factor.

- Total steady-state (sealed) VA is the volt-amperes that the transformer must deliver to the load circuit for an extended period of time — the amount of current required to hold the contact in the circuit.
- Total inrush VA is the volt amperes that the transformer must deliver upon initial energization of the control circuit. Energization of electromagnetic devices takes 30...50 milliseconds. During this inrush period, the electromagnetic control devices draw many times normal current — 3...10 times normal is typical.
- Inrush load power factor is difficult to determine without detailed vector analysis of all the load components. Such an analysis is generally not feasible. Therefore, a safe assumption is 40% power factor.

Selection Process

1. Determine the total inrush VA of the control circuits from the table below. Do not neglect the current requirements of indicating lights and other devices that do not have an inrush VA but are re-energized at the same time as the other components in the circuit. Their total VA should be added to the total inrush VA.
2. Refer to the table below, *Regulation Data — Inrush VA*. If the supply circuit voltage (Step 1) is reasonably stable and fluctuates not more than ± 5%, refer to the 90% secondary voltage column. If it fluctuates as much as ± 10%, refer to the 95% secondary voltage column. Go down the column selected until at the inrush VA closest to, but not less than, the inrush VA of the control circuit.

3. Read to the far left side of the chart. The transformer's continuous nominal VA rating is now selected. The secondary voltage that will be delivered under inrush conditions will be either 85%, 90%, or 95% of the rated secondary voltage, depending on the column selected from the table below, *Regulation Data — Inrush VA*. The total sealed VA of the control circuit must not exceed the nominal VA rating of the transformer selected from the table below.
4. Refer to the specification tables on the following pages to select a transformer according to the required continuous nominal VA, and primary and secondary voltage combinations.

Regulation Data — Inrush VA

Inrush VA at 40% Power Factor				Power Factor Adjustments	
Nominal VA Rating	85%	90%	95%	Power Factor	Multiply By
50	158	139	116	100%	0.63
75	242	213	177	90%	0.65
100	346	302	249	80%	0.70
150	528	461	379	70%	0.75
200	869	743	585	60%	0.82
250	1057	904	719	50%	0.90
300	1418	1200	937	40%	1.00
350	1620	1361	1047	30%	1.12
500	2681	2221	1648	20%	1.27
750	4560	3718	2700	10%	1.45
1000	7568	6118	4185	—	—
1500	15724	12423	8203	—	—
2000	16941	13660	9484	—	—
3000	25680	20180	13797	—	—

Note: Refer to this page for information on how to select a machine tool transformer.

Transformer without Primary or Secondary Fuse Block/Clip†

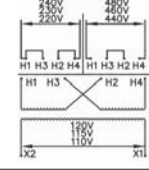
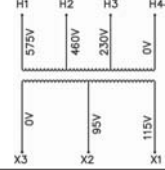
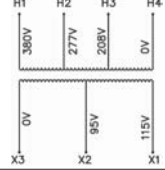
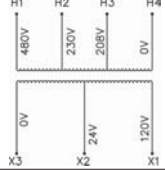
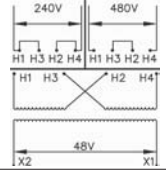
Continuous VA	Cat. Nos.				
	Primary 220x440V, 230x460V, 240x480V (50/60 Hz) 	Primary 230/460/575V (50/60 Hz) 	Primary 208/277/380V (50/60 Hz) 	Primary 208/230/480V (50/60 Hz) 	Primary 240X480V (50/60 Hz) 
	Secondary 110, 115, 120V	Secondary 115/95V	Secondary 115/95V	Secondary 120/24V	Secondary 48V
50	1497A-A1-M6-0-N	1497A-A1-M7-0-N	1497A-A1-M8-0-N	1497A-A1-M18-0-N	1497A-A1-M19-0-N
75	1497A-A2-M6-0-N	1497A-A2-M7-0-N	1497A-A2-M8-0-N	1497A-A2-M18-0-N	1497A-A2-M19-0-N
100	1497A-A3-M6-0-N	1497A-A3-M7-0-N	1497A-A3-M8-0-N	1497A-A3-M18-0-N	1497A-A3-M19-0-N
150	1497A-A4-M6-0-N	1497A-A4-M7-0-N	1497A-A4-M8-0-N	1497A-A4-M18-0-N	1497A-A4-M19-0-N
200	1497A-A5-M6-0-N	1497A-A5-M7-0-N	1497A-A5-M8-0-N	1497A-A5-M18-0-N	1497A-A5-M19-0-N
250	1497A-A6-M6-0-N	1497A-A6-M7-0-N	1497A-A6-M8-0-N	1497A-A6-M18-0-N	1497A-A6-M19-0-N
300	1497A-A7-M6-0-N	1497A-A7-M7-0-N	1497A-A7-M8-0-N	1497A-A7-M18-0-N	1497A-A7-M19-0-N
350	1497A-A8-M6-0-N	1497A-A8-M7-0-N	1497A-A8-M8-0-N	1497A-A8-M18-0-N	1497A-A8-M19-0-N
500	1497A-A9-M6-0-N	1497A-A9-M7-0-N	1497A-A9-M8-0-N	—	1497A-A9-M19-0-N
750	1497A-A10-M6-0-N	1497A-A10-M7-0-N	1497A-A10-M8-0-N	—	1497A-A10-M19-0-N
1000	1497A-A11-M6-0-N	1497A-A11-M7-0-N	1497A-A11-M8-0-N	—	1497A-A11-M19-0-N
1500	1497A-A12-M6-0-N	1497A-A12-M7-0-N	1497A-A12-M8-0-N	—	—
2000	1497A-A13-M6-0-N	1497A-A13-M7-0-N	1497A-A13-M8-0-N	—	—
3000	1497A-A14-M6-0-N	—	—	—	—

Note: Refer to 8-44 for information on how to select a machine tool transformer.

Transformer with 1 Secondary Fuse Block/Clip‡

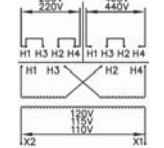
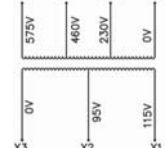
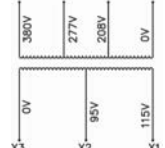
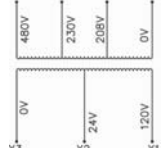
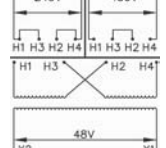
Continuous VA	Cat. Nos.				
	Primary 220x440V, 230x460V, 240x480V (50/60 Hz) 	Primary 230/460/575V (50/60 Hz) 	Primary 208/277/380V (50/60 Hz) 	Primary 208/230/480V (50/60 Hz) 	Primary 240X480V (50/60 Hz) 
	Secondary 110, 115, 120V	Secondary 115/95V	Secondary 115/95V	Secondary 120/24V	Secondary 48V
50	1497A-A1-M6-1-N	1497A-A1-M7-1-N	1497A-A1-M8-1-N	1497A-A1-M18-1-N	1497A-A1-M19-1-N
75	1497A-A2-M6-1-N	1497A-A2-M7-1-N	1497A-A2-M8-1-N	1497A-A2-M18-1-N	1497A-A2-M19-1-N
100	1497A-A3-M6-1-N	1497A-A3-M7-1-N	1497A-A3-M8-1-N	1497A-A3-M18-1-N	1497A-A3-M19-1-N
150	1497A-A4-M6-1-N	1497A-A4-M7-1-N	1497A-A4-M8-1-N	1497A-A4-M18-1-N	1497A-A4-M19-1-N
200	1497A-A5-M6-1-N	1497A-A5-M7-1-N	1497A-A5-M8-1-N	1497A-A5-M18-1-N	1497A-A5-M19-1-N
250	1497A-A6-M6-1-N	1497A-A6-M7-1-N	1497A-A6-M8-1-N	1497A-A6-M18-1-N	1497A-A6-M19-1-N
300	1497A-A7-M6-1-N	1497A-A7-M7-1-N	1497A-A7-M8-1-N	1497A-A7-M18-1-N	1497A-A7-M19-1-N
350	1497A-A8-M6-1-N	1497A-A8-M7-1-N	1497A-A8-M8-1-N	1497A-A8-M18-1-N	1497A-A8-M19-1-N
500	1497A-A9-M6-1-N	1497A-A9-M7-1-N	1497A-A9-M8-1-N	—	1497A-A9-M19-1-N
750	1497A-A10-M6-1-N	1497A-A10-M7-1-N	1497A-A10-M8-1-N	—	1497A-A10-M19-1-N
1000	1497A-A11-M6-1-N	1497A-A11-M7-1-N	1497A-A11-M8-1-N	—	1497A-A11-M19-1-N
1500	1497A-A12-M6-1-N	1497A-A12-M7-1-N	1497A-A12-M8-1-N	—	—
2000	1497A-A13-M6-1-N	1497A-A13-M7-1-N	1497A-A13-M8-1-N	—	—
3000	1497A-A14-M6-1-N	—	—	—	—

‡ Secondary Fuse Block/Clip: Transformers rated 350VA and below use secondary fuse clips. Transformers rated 500VA and above use secondary fuse blocks.

Transformer with 2 Primary and 1 Secondary Fuse Block/Clip‡

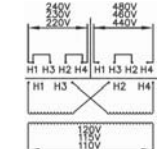
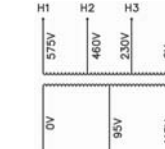
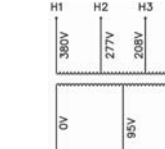
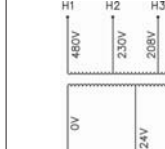
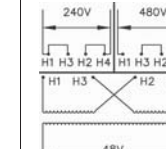
Continuous VA	Cat. Nos.				
	Primary 220x440V, 230x460V, 240x480V (50/60 Hz) 	Primary 230/460/575V (50/60 Hz) 	Primary 208/277/380V (50/60 Hz) 	Primary 208/230/480V (50/60 Hz) 	Primary 240X480V (50/60 Hz) 
	Secondary 110, 115, 120V	Secondary 115/95V	Secondary 115/95V	Secondary 120/24V	Secondary 48V
50	1497A-A1-M6-3-N	1497A-A1-M7-3-N	1497A-A1-M8-3-N	1497A-A1-M18-3-N	1497A-A1-M19-3-N
75	1497A-A2-M6-3-N	1497A-A2-M7-3-N	1497A-A2-M8-3-N	1497A-A2-M18-3-N	1497A-A2-M19-3-N
100	1497A-A3-M6-3-N	1497A-A3-M7-3-N	1497A-A3-M8-3-N	1497A-A3-M18-3-N	1497A-A3-M19-3-N
150	1497A-A4-M6-3-N	1497A-A4-M7-3-N	1497A-A4-M8-3-N	1497A-A4-M18-3-N	1497A-A4-M19-3-N
200	1497A-A5-M6-3-N	1497A-A5-M7-3-N	1497A-A5-M8-3-N	1497A-A5-M18-3-N	1497A-A5-M19-3-N
250	1497A-A6-M6-3-N	1497A-A6-M7-3-N	1497A-A6-M8-3-N	1497A-A6-M18-3-N	1497A-A6-M19-3-N
300	1497A-A7-M6-3-N	1497A-A7-M7-3-N	1497A-A7-M8-3-N	1497A-A7-M18-3-N	1497A-A7-M19-3-N
350	1497A-A8-M6-3-N	1497A-A8-M7-3-N	1497A-A8-M8-3-N	1497A-A8-M18-3-N	1497A-A8-M19-3-N
500	1497A-A9-M6-3-N	1497A-A9-M7-3-N	1497A-A9-M8-3-N	—	1497A-A9-M19-3-N
750	1497A-A10-M6-3-N	1497A-A10-M7-3-N	1497A-A10-M8-3-N	—	1497A-A10-M19-3-N
1000	1497A-A11-M6-3-N	1497A-A11-M7-3-N	1497A-A11-M8-3-N	—	1497A-A11-M19-3-N
1500	1497A-A12-M6-3-N	1497A-A12-M7-3-N	1497A-A12-M8-3-N	—	—
2000	1497A-A13-M6-3-N	1497A-A13-M7-3-N	1497A-A13-M8-3-N	—	—
3000	1497A-A14-M6-3-N	—	—	—	—

‡ Secondary Fuse Block/Clip: Transformers rated 350VA and below use secondary fuse clips. Transformers rated 500VA and above use secondary fuse blocks.

Machine Tool Transformers

Product Selection, Continued

Fuse Sizing Charts

Important: Select the fuse to protect the control circuit conductors in accordance with the National Electrical Code.

Primary Fuse Sizing Chart (When Only Primary Protection is Used)

Maximum Amp Rating for Current Limiting Fuses Based on Transformer Primary Voltage and the National Electrical Code

VA	115V	120V	200V	208V	220V	230V	240V	277V	380V	400V	415V	440V	460V	480V	500V	550V	575V	600V
50	1.25	1.25	0.75	0.6	0.6	0.6	0.6	0.5	0.3	0.3	0.3	0.3	0.3	0.3	0.3	0.25	0.25	0.25
75	1.8	1.8	1.125	1	1	0.75	0.75	0.75	0.5	0.5	0.5	0.5	0.4	0.4	0.4	0.4	0.3	0.3
100	2.5	2.5	1.5	1.4	1.25	1.25	1.25	1	0.75	0.75	0.6	0.6	0.6	0.6	0.6	0.5	0.5	0.5
150	3.5	3.5	2.25	2	2	1.8	1.8	1.6	1.125	1.125	1	1	0.75	0.75	0.75	0.75	0.75	0.75
200	5	5	3	2.8	2.5	2.5	2.5	2	1.5	1.5	1.4	1.25	1.25	1.25	1.125	1	1	1
250	3.5	3.2	3.5	3.5	3.2	3.2	3	2.5	1.8	1.8	1.8	1.6	1.6	1.5	1.5	1.25	1.25	1.25
300	4	4	4.5	4	4	3.5	3.5	3.2	2.25	2.25	2	2	1.8	1.8	1.8	1.6	1.5	1.5
350	5	4.5	5	5	4.5	4.5	4	3.5	2.5	2.5	2.5	2.25	2.25	2	2	1.8	1.8	1.6
500	7	6.25	4	4	3.5	3.5	3.2	5	3.5	3.5	3.5	3.2	3.2	3	3	2.5	2.5	2.5
750	10	10	6.25	6	5.6	5	5	4.5	5.6	5.6	5	5	4.5	4.5	4.5	4	3.5	3.5
1000	12	12	8	8	7	7	6.25	6	4	4	4	3.5	3.5	3.2	3.2	5	5	5
1500	20	15	12	12	10	10	10	9	6.25	6.25	6	5.6	5	5	5	4.5	4	4
2000	20	20	12	12	10	12	12	12	8	8	8	7	7	6.25	6.25	6	5.6	5
3000	30	30	15	15	15	15	15	12	12	12	12	10	10	10	10	9	8	8

Primary Fuse Sizing Chart (When Primary and Secondary Protection is Used)

Maximum Amp Rating for Current Limiting Fuses Based on Transformer Primary Voltage and the National Electrical Code

VA	115V	120V	200V	208V	220V	230V	240V	277V	380V	400V	415V	440V	460V	480V	500V	550V	575V	600V
50	1	1	0.6	0.6	0.5	0.5	0.5	0.4	0.3	0.3	0.3	0.25	0.25	0.25	0.25	0.2	0.2	0.2
75	1.6	1.5	0.75	0.75	0.75	0.75	0.75	0.6	0.4	0.4	0.4	0.4	0.4	0.3	0.3	0.3	0.3	0.3
100	2	2	1.25	1.125	1.125	1	1	0.75	0.6	0.6	0.6	0.5	0.5	0.5	0.5	0.4	0.4	0.4
150	3.2	3	1.8	1.8	1.6	1.6	1.5	1.25	0.75	0.75	0.75	0.75	0.75	0.75	0.75	0.6	0.6	0.6
200	4	4	2.5	2.25	2	2	2	1.8	1.25	1.25	1.125	1.125	1	1	1	0.75	0.75	0.75
250	5	5	3	3	2.8	2.5	2.5	2.25	1.6	1.5	1.5	1.4	1.25	1.25	1.25	1.125	1	1
300	6.25	6.25	3.5	3.5	3.2	3.2	3	2.5	1.8	1.8	1.8	1.6	1.6	1.5	1.5	1.25	1.25	1.25
350	7	7	4	4	3.5	3.5	3.5	3	2.25	2	2	1.8	1.8	1.8	1.6	1.5	1.5	1.4
500	10	10	6.25	6	5.6	5	5	4.5	3.2	3	3	2.8	2.5	2.5	2.5	2.25	2	2
750	15	15	9	9	8	8	7	6.25	4.5	4.5	4.5	4	4	3.5	3.5	3.2	3.2	3
1000	20	20	12	12	10	10	10	9	6.25	6.25	6	5.6	5	5	5	4.5	4	4
1500	30	30	15	15	15	15	15	12	9	9	9	8	8	7	7	6.25	6.25	6.25
2000	40	40	25	20	20	20	20	15	12	12	12	10	10	10	10	9	8	8
3000	45	45	35	35	30	30	30	25	15	15	15	15	15	15	15	12	12	12

Secondary Fuse Sizing Chart

Maximum Amp Rating for Current Limiting Fuses Based on the National Electrical Code

VA	23V	24V	25V	85V	90V	95V	100V	110V	115V	120V	125V	130V	220V	230V	240V
50	3.5	3.2	3.2	0.75	0.75	0.75	0.75	0.75	0.6	0.6	0.6	0.6	0.3	0.3	0.3
75	5	5	5	1.4	1.25	1.25	1.25	1.125	1	1	1	0.75	0.5	0.5	0.5
100	7	6.25	6.25	1.8	1.8	1.6	1.6	1.5	1.4	1.25	1.25	1.25	0.75	0.6	0.6
150	10	10	10	2.8	2.5	2.5	2.5	2.25	2	2	2	1.8	1.125	1	1
200	12	12	12	3.5	3.5	3.5	3.2	3	2.8	2.5	2.5	2.5	1.5	1.4	1.25
250	15	15	15	4.5	4.5	4	4	3.5	3.5	3.2	3.2	3.2	1.8	1.8	1.6
300	20	20	20	5.6	5	5	5	4.5	4	4	4	3.5	2.25	2	2
350	20	20	20	6.25	6.25	6	5.6	5	5	4.5	4.5	4	2.5	2.5	2.25
500	—	—	—	9	9	8	8	7	7	6.25	6.25	6.25	3.5	3.5	3.2
750	—	—	—	12	12	12	12	10	10	10	10	9	5.6	5	5
1000	—	—	—	15	15	15	15	15	12	12	12	12	7	7	6.25
1500	—	—	—	25	25	25	25	20	20	20	20	15	10	10	10
2000	—	—	—	35	35	35	30	30	25	25	25	25	15	12	12
3000	—	—	—	—	—	—	—	45	40	40	40	35	20	20	20

Dimensions are shown in inches (millimeters). Dimensions are not intended to be used for manufacturing purposes.

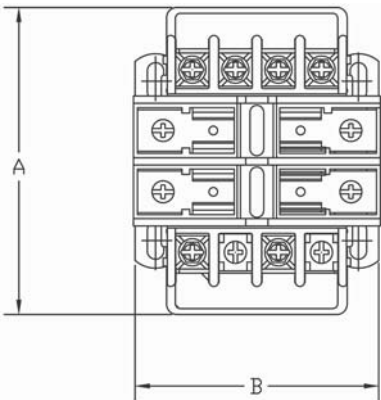

Transformer with 2 Primary Fuse Blocks and 0 or 1 Secondary Fuse Block/Clip (Top View)

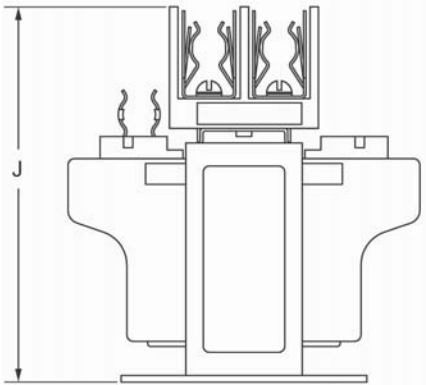

Transformer with 2 Primary Fuse Blocks and 1 Secondary Fuse Block/Clip (Side View)

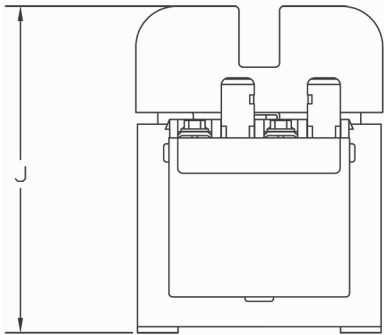

Transformer with 2 Primary Fuse Blocks and 1 Secondary Fuse Block/Clip (Side View)

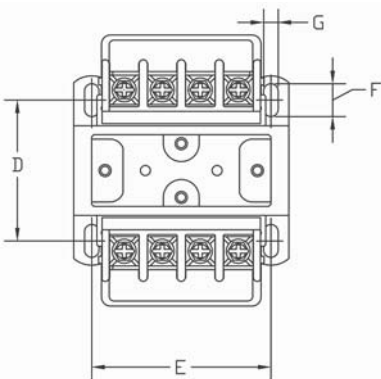

Transformer with 0 Primary Fuse Blocks and 0 or 1 Secondary Fuse Block/Clip (Top View)

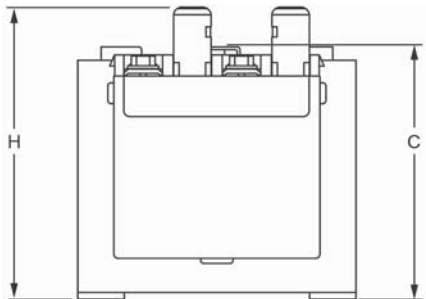

Transformer with 0 Primary Fuse Block and 1 Secondary Fuse Block/Clip (Side View)

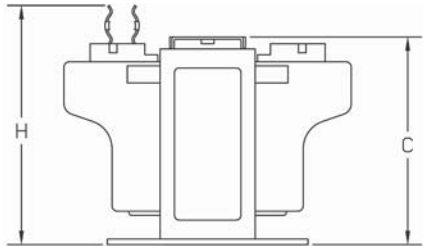

Transformer with 0 Primary Fuse Blocks and 1 Secondary Fuse Block/Clip (Side View)

VA	Cat. No.	A	B	C	D	E	F	G	H	J	Approx. Shipping Wt. lbs (kg)
50	1497A-A1-M6-__-N	3-25/32 (96)	3 (76)	2-23/32 (69)	1-31/32 (50)	2-1/2 (64)	15/32 (12)	1/5 (5)	3-9/64 (80)	4-1/32 (102)	3 (1.4)
	1497A-A1-M7-__-N	4-1/32 (102)			2-1/5 (56)						4 (1.8)
	1497A-A1-M8-__-N	4-17/32 (115)			2-53/64 (72)						4 (1.8)
	1497A-A1-M19-__-N	3-25/32 (96)			1-31/32 (50)						4 (1.8)
75	1497A-A2-M6-__-N	4-1/32 (102)	3 (76)	2-23/32 (69)	2-27/64 (61)	2-1/2 (64)	15/32 (12)	1/5 (5)	3-9/64 (80)	4-1/32 (102)	4 (1.8)
	1497A-A2-M7-__-N	4-17/32 (115)			2-5/8 (67)						5 (2.3)
	1497A-A2-M8-__-N	4-17/32 (115)	3-3/8 (86)	3-3/64 (77)	3 (76)	2-13/16 (71)			3-15/32 (88)	4-23/64 (110)	5 (2.3)
	1497A-A2-M18-__-N		3 (76)	2-23/32 (69)	2-27/64 (61)	2-1/2 (64)			3-9/64 (80)	4-1/32 (102)	5 (2.3)
100	1497A-A3-M6-__-N	4 (102)	3-3/8 (86)	3-3/64 (77)	2-27/64 (61)	2-13/16 (71)	15/32 (12)	1/5 (5)	3-15/32 (88)	4-23/64 (110)	5 (2.3)
	1497A-A3-M7-__-N	4-1/16 (103)	3-3/4 (95)	3-23/64 (85)	2-13/16 (71)	3-5/16 (80)			3-49/64 (96)	4-21/32 (118)	6 (2.7)
	1497A-A3-M8-__-N	4-17/32 (115)			3 (76)				3-15/32 (88)	4-23/64 (110)	6 (2.7)
	1497A-A3-M19-__-N	4 (102)	3-3/8 (86)	3-3/64 (77)	2-27/64 (61)	2-13/16 (71)			3-15/32 (88)	4-23/64 (110)	6 (2.7)

Machine Tool Transformers

Approximate Dimensions, Continued

VA	Cat. No.	A	B	C	D	E	F	G	H	J	Approx. Shipping Wt. lbs (kg)										
150	1497A-A4-M6-__-N	4-1/16 (103)	3-3/4 (95)	3-23/64 (85)	2-13/16 (71)	3-5/16 (80)	15/32 (12)	1/5 (5)	3-49/64 (96)	4-21/32 (118)	6 (2.7)										
	1497A-A4-M7-__-N	4-17/32 (115)			3-3/16 (81)				3-25/32 (96)		7 (3.2)										
	1497A-A4-M8-__-N	5-1/16 (129)							3-49/64 (96)		7 (3.2)										
	1497A-A4-M18-__-N	4-1/16 (103)							2-13/16 (71)		7 (3.2)										
	1497A-A4-M19-__-N																				
200	1497A-A5-M6-__-N	4-3/8 (111)	4-1/2 (114)	3-31/32 (101)	2-5/8 (67)	3-3/4 (95)	15/32 (12)	1/5 (5)	4-2/5 (112)	5-9/32 (134)	10 (4.5)										
	1497A-A5-M7-__-N				2-63/64 (76)						10 (4.5)										
	1497A-A5-M8-__-N										2-5/8 (67)	10 (4.5)									
	1497A-A5-M18-__-N																				
	1497A-A5-M19-__-N																				
250	1497A-A6-M6-__-N	4-3/8 (111)	4-1/2 (114)	3-31/32 (101)	2-53/64 (72)	3-3/4 (95)	15/32 (12)	1/5 (5)	4-2/5 (112)	5-9/32 (134)	10 (4.5)										
	1497A-A6-M7-__-N				3-15/32 (88)						10 (4.5)										
	1497A-A6-M8-__-N										2-53/64 (72)	10 (4.5)									
	1497A-A6-M18-__-N										4-3/4 (120)										
	1497A-A6-M19-__-N										4-3/8 (111)										
300	1497A-A7-M6-__-N	4-3/4 (120)	4-1/2 (114)	3-31/32 (101)	3-3/16 (81)	3-3/4 (95)	15/32 (12)	1/5 (5)	4-2/5 (112)	5-9/32 (134)	12 (5.4)										
	1497A-A7-M7-__-N				3-7/8 (98)						12 (5.4)										
	1497A-A7-M8-__-N										4-3/8 (111)	1-1/16 (27)	5/16 (8)	4-2/5 (112)	5-15/16 (151)	12 (5.4)					
	1497A-A7-M18-__-N										6-7/64 (155)	5-1/4 (133)	4-5/8 (118)	3-31/32 (101)	3-3/16 (81)	3-3/4 (95)	15/32 (12)	1/5 (5)	4-2/5 (112)	5-9/32 (134)	12 (5.4)
	1497A-A7-M19-__-N										4-3/4 (120)	4-1/2 (114)	3-31/32 (101)	3-3/16 (81)	3-3/4 (95)	15/32 (12)	1/5 (5)	4-2/5 (112)	5-9/32 (134)	12 (5.4)	
350	1497A-A8-M6-__-N	4-3/4 (120)	4-1/2 (114)	3-31/32 (101)	3-3/16 (81)	3-3/4 (95)	15/32 (12)	1/5 (5)	4-2/5 (112)	5-9/32 (134)	12 (5.4)										
	1497A-A8-M7-__-N	4-63/64 (128)			3-3/4 (95)						14 (6.4)										
	1497A-A8-M8-__-N	6-7/64 (155)									5-1/4 (133)	4-5/8 (118)	3-7/8 (98)	4-3/8 (111)	1-1/16 (27)	5/16 (8)	4-2/5 (112)	5-15/16 (151)	14 (6.4)		
	1497A-A8-M18-__-N	4-3/4 (120)									4-1/2 (114)	3-31/32 (101)	3-3/16 (81)	3-3/4 (95)	15/32 (12)	1/5 (5)	4-2/5 (112)	5-9/32 (134)	14 (6.4)		
	1497A-A8-M19-__-N																				
500	1497A-A9-M6-__-N	6-7/64 (155)	5-1/4 (133)	4-5/8 (118)	3-7/8 (98)	4-3/8 (111)	1-1/16 (27)	5/16 (8)	4-2/5 (112)	5-15/16 (151)	19 (8.6)										
	1497A-A9-M7-__-N										18 (8.2)										
	1497A-A9-M8-__-N										18 (8.2)										
	1497A-A9-M19-__-N																				
750	1497A-A10-M6-__-N	7-39/64 (193)	5-1/4 (133)	4-5/8 (118)	5-7/8 (149)	4-3/8 (111)	1-1/16 (27)	5/16 (8)	4-2/5 (112)	5-15/16 (151)	28 (12.7)										
	1497A-A10-M7-__-N	8-7/64 (206)									32 (14.5)										
	1497A-A10-M8-__-N	7-39/64 (193)									31 (14.1)										
	1497A-A10-M19-__-N										31 (14.1)										
1000	1497A-A11-M6-__-N	7-7/64 (181)	6-3/4 (171)	5-55/64 (149)	4-31/32 (126)	6-1/8 (155)	9/10 (23)	5/16 (8)	4-2/5 (112)	7-3/16 (183)	40 (18.1)										
	1497A-A11-M7-__-N										42 (19.1)										
	1497A-A11-M8-__-N										41 (18.6)										
	1497A-A11-M19-__-N										41 (18.6)										
1500	1497A-A12-M6-__-N	8-7/64 (206)	6-3/4 (171)	5-55/64 (149)	6-1/8 (155)	6-1/8 (155)	7/8 (22)	5/16 (8)	4-2/5 (112)	7-3/16 (183)	53 (24)										
	1497A-A12-M7-__-N										55 (24.9)										
	1497A-A12-M8-__-N										54 (24.5)										
2000	1497A-A13-M6-__-N	8-7/64 (206)	6-3/4 (171)	5-55/64 (149)	6-1/8 (155)	6-1/8 (155)	7/8 (22)	5/16 (8)	4-2/5 (112)	7-3/16 (183)	53 (24)										
	1497A-A13-M7-__-N	9 (229)									61 (27.7)										
	1497A-A13-M8-__-N										58 (26.3)										
3000	1497A-A14-M6-__-N	8 (203)	9 (229)	7-41/64 (194)	5-1/4 (133)	7-1/2 (191)	9/10 (23)	7/16 (11)	4-2/5 (112)	8-61/64 (227)	72 (32.7)										



Bulletin 1497B — Control Power Transformers

Bulletin 1497B Control Power Transformers are designed to reduce supply voltages to control circuits. The complete line of transformers is available with optional factory-installed or panel-mount primary and secondary fuse block.

- 50...3000VA (60 Hz)
- RoHS compliant
- Single phase
- Epoxy encapsulated

Table of Contents

Product Selection 8-50
 Approximate Dimensions..... 8-53
 Accessories..... 8-63

Standards Compliance

C22.2 No. 66
 UL 506

Certifications

cULus Listed (File No. E52057, Guide No. XPTQ, XPTQ7)

Catalog Number Explanation

Bulletin 1497B Control Power Transformers

1497B – A3 – M11 – 0 – N
 a *b* *c* *d*

a

VA Rating	
Code	Description [VA]
A1	50
A2	75
A3	100
A4	150
A5	200
A6	250
A7	300
A9	500
A10	750
A11	1000
A12	1500
A13	2000
A14	3000

b

Primary and Secondary Voltage		
Code	Primary	Secondary
M11	600/575/550V	120X240V (60 Hz)
M12	120X240V	120X240V (60 Hz)
M13	120X240V	24V (60 Hz)
M14	240X480V	120X240V (60 Hz)
M15	380/400/416V	115X230V (60 Hz)
M16	240X480V	24V (60 Hz)
M17	208/240V	24V (60 Hz)

c

Fuse Block Options*	
Code	Block Options
0	0 Primary, 0 Secondary
1	0 Primary, 1 Secondary
2	2 Primary, 0 Secondary
3	2 Primary, 1 Secondary

d

Factory Installed Options	
Code	Description
N	No Taps

Note: For complete list of valid transformer configurations, see page 8-50.

* Transformers rated 350VA and below use secondary fuse clips. Transformers rated 500VA and above use secondary fuse blocks.

Control Power Transformers

Product Selection

Selecting a Control Power Transformer

For proper transformer selection, three characteristics of the load circuit must be determined in addition to the minimum voltage required to operate the circuit. These are total steady-state (sealed) VA, total inrush VA, and inrush load power factor.

- Total steady-state (sealed) VA is the volt-amperes that the transformer must deliver to the load circuit for an extended period of time — the amount of current required to hold the contact in the circuit.
- Total inrush VA is the volt amperes that the transformer must deliver upon initial energization of the control circuit. Energization of electromagnetic devices takes 30...50 milliseconds. During this inrush period, the electromagnetic control devices draw many times normal current — 3...10 times normal is typical.
- Inrush load power factor is difficult to determine without detailed vector analysis of all the load components. Such an analysis is generally not feasible. Therefore, a safe assumption is 40% power factor.

Selection Process

1. Determine the total inrush VA of the control circuits from the table below, *Typical Magnetic Motor Starter and Contactor Data 60 Hz, 120 Volt, 3-Pole*. Do not neglect the current requirements of indicating lights and other devices that do not have an inrush VA but are re-energized at the same time as the other components in the circuit. Their total VA should be added to the total inrush VA.
2. Refer to the table below, *Regulation Data — Inrush VA*. If the supply circuit voltage (Step 1) is reasonably stable and fluctuates not more than ± 5%, refer to the 90% secondary voltage column. If it fluctuates as much as ± 10%, refer to the 95% secondary voltage column. Go down the column selected until at the inrush VA closest to, but not less than, the inrush VA of the control circuit.
3. Read to the far left side of the chart. The transformer's continuous nominal VA rating is now selected. The secondary voltage that will be delivered under inrush conditions will be either 85%, 90%, or 95% of the rated secondary voltage, depending on the column selected from the table below, *Regulation Data — Inrush VA*. The total sealed VA of the control circuit must not exceed the nominal VA rating of the transformer selected from the table below, *Typical Magnetic Motor Starter and Contactor Data 60 Hz, 120 Volt, 3-Pole*.
4. Refer to the specification tables on the following pages to select a transformer according to the required continuous nominal VA, and primary and secondary voltage combinations.

Regulation Data — Inrush VA

Nominal VA Rating	Inrush VA at 40% Power Factor			Power Factor Adjustments	
	85%	90%	95%	Power Factor	Multiply By
50	158	139	116	100%	0.63
75	242	213	177	90%	0.65
100	346	302	249	80%	0.70
150	528	461	379	70%	0.75
200	869	743	585	60%	0.82
250	1057	904	719	50%	0.90
300	1418	1200	937	40%	1.00
500	2681	2221	1648	20%	1.27
750	4560	3718	2700	10%	1.45
1000	7568	6118	4185	—	—
1500	15724	12423	8203	—	—
2000	16941	13660	9484	—	—
3000	25680	20180	13797	—	—

Transformers without Fusing Block/Clip

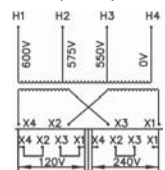
Continuous VA	Primary — 600/575/550V (60 Hz)	Primary — 120x240V (60 Hz)
		
	Secondary — 120X240V (60 Hz)	Secondary — 120X240V (60 Hz)
	Cat. No.	Cat. No.‡
100	1497B-A3-M11-0-N	1497B-A3-M12-0-N
200	1497B-A5-M11-0-N	1497B-A5-M12-0-N
300	1497B-A7-M11-0-N	1497B-A7-M12-0-N
500	1497B-A9-M11-0-N	1497B-A9-M12-0-N
750	—	1497B-A10-M12-0-N
1000	1497B-A11-M11-0-N	1497B-A11-M12-0-N
2000	1497B-A13-M11-0-N	1497B-A13-M12-0-N
3000	1497B-A14-M11-0-N	1497B-A14-M12-0-N

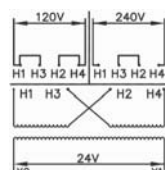
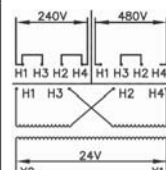
Continuous VA	Primary — 120x240V (60 Hz)	Primary — 240x480V (60 Hz)	Primary — 208/240V (60 Hz)
			
	Secondary — 24V (60 Hz)	Secondary — 24V (60 Hz)	Secondary — 24V (60 Hz)
	Cat. No.	Cat. No.	Cat. No.
50	1497B-A1-M13-0-N	1497B-A1-M16-0-N	1497B-A1-M17-0-N
75	1497B-A2-M13-0-N	—	—
100	1497B-A3-M13-0-N	1497B-A3-M16-0-N	1497B-A3-M17-0-N
150	1497B-A4-M13-0-N	1497B-A4-M16-0-N	1497B-A4-M17-0-N
200	1497B-A5-M13-0-N	—	—
250	1497B-A6-M13-0-N	1497B-A6-M16-0-N	1497B-A6-M17-0-N
300	1497B-A7-M13-0-N	—	—

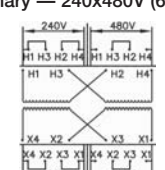
Continuous VA	Primary — 240x480V (60 Hz)	Primary — 380/400/416V (60 Hz)
		
	Secondary — 120X240V (60 Hz)	Secondary — 115X230V (60 Hz)
	Cat. No.	Cat. No.‡
100	1497B-A3-M14-0-N	—
150	1497B-A4-M14-0-N	—
200	1497B-A6-M14-0-N	—
500	1497B-A9-M14-0-N	1497B-A9-M15-0-N
750	1497B-A10-M14-0-N	1497B-A10-M15-0-N
1000	1497B-A11-M14-0-N	1497B-A11-M15-0-N
1500	1497B-A12-M14-0-N	1497B-A12-M15-0-N
2000	1497B-A13-M14-0-N	1497B-A13-M15-0-N
3000	1497B-A14-M14-0-N	1497B-A14-M15-0-N

‡ No secondary fusing available

Note: Refer to page 8-50 for information on how to select a control power transformer.

Transformers with 2 Primary and 0 Secondary Fuse Block/Clip‡

Continuous VA	Primary — 600/575/550V (60 Hz)	Primary — 120x240V (60 Hz)
	Secondary — 120X240V (60 Hz)	Secondary — 120X240V (60 Hz)
	Cat. No.	Cat. No.
100	1497B-A3-M11-2-N	1497B-A3-M12-2-N
200	1497B-A5-M11-2-N	1497B-A5-M12-2-N
300	1497B-A7-M11-2-N	1497B-A7-M12-2-N

Note: Refer to page 8-50 for information on how to select a control power transformer.

Transformers with 2 Primary and 1 Secondary Fuse Block/Clip‡

Continuous VA	Primary — 120x240V (60 Hz)	Primary — 240x480V (60 Hz)	Primary — 208/240V (60 Hz)
	Secondary — 24V (60 Hz)	Secondary — 24V (60 Hz)	Secondary — 24V (60 Hz)
	Cat. No.	Cat. No.	Cat. No.
50	1497B-A1-M13-3-N	1497B-A1-M16-3-N	1497B-A1-M17-3-N
75	1497B-A2-M13-3-N	—	—
100	1497B-A3-M13-3-N	1497B-A3-M16-3-N	1497B-A3-M17-3-N
150	1497B-A4-M13-3-N	1497B-A4-M16-3-N	1497B-A4-M17-3-N
200	1497B-A5-M13-3-N	—	—
250	1497B-A6-M13-3-N	1497B-A6-M16-3-N	1497B-A6-M17-3-N
300	1497B-A7-M13-3-N	—	—

Continuous VA	Primary — 600/575/550V (60 Hz)	Primary — 120x240V (60 Hz)	Primary — 240x480V (60 Hz)	Primary — 380/400/416V (60 Hz)
	Secondary — 120X240V (60 Hz)	Secondary — 120X240V (60 Hz)	Secondary — 120X240V (60 Hz)	Secondary — 115X230V (60 Hz)
	Cat. No.	Cat. No.	Cat. No.	Cat. No.
500	1497B-A9-M11-3-N	1497B-A9-M12-3-N	1497B-A9-M14-3-N	1497B-A9-M15-3-N
750	—	1497B-A10-M12-3-N	1497B-A10-M14-3-N	1497B-A10-M15-3-N
1000	1497B-A11-M11-3-N	1497B-A11-M12-3-N	1497B-A11-M14-3-N	1497B-A11-M15-3-N
1500	—	—	1497B-A12-M14-3-N	1497B-A12-M15-3-N
2000	1497B-A13-M11-3-N	1497B-A13-M12-3-N	1497B-A13-M14-3-N	1497B-A13-M15-3-N
3000	1497B-A14-M11-3-N	1497B-A14-M12-3-N	1497B-A14-M14-3-N	1497B-A14-M15-3-N

‡ Secondary Fuse Block/Clip: Transformers rated 350VA and below use secondary fuse clips. Transformers rated 500VA and above use secondary fuse blocks.

Transformers with 0 Primary and 1 Secondary Fuse Block/Clip‡

Continuous VA	Primary — 120x240V (60 Hz)	Primary — 240x480V (60 Hz)	Primary — 208/240V (60 Hz)
	Secondary — 24V (60 Hz)	Secondary — 24V (60 Hz)	Secondary — 24V (60 Hz)
	Cat. No.	Cat. No.	Cat. No.
50	1497B-A1-M13-1-N	1497B-A1-M16-1-N	1497B-A1-M17-1-N
75	1497B-A2-M13-1-N	—	—
100	1497B-A3-M13-1-N	1497B-A3-M16-1-N	1497B-A3-M17-1-N
150	1497B-A4-M13-1-N	1497B-A4-M16-1-N	1497B-A4-M17-1-N
200	1497B-A5-M13-1-N	—	—
250	1497B-A6-M13-1-N	1497B-A6-M16-1-N	1497B-A6-M17-1-N
300	1497B-A7-M13-1-N	—	—

‡ Secondary Fuse Block/Clip: Transformers rated 350VA and below use secondary fuse clips. Transformers rated 500VA and above use secondary fuse blocks.

Control Power Transformers

Product Selection, Continued

Fuse Sizing Charts

Important: Select the fuse to protect the control circuit conductors in accordance with the National Electrical Code.

Primary Fuse Sizing Chart (When Only Primary Protection is Used)

Maximum Amp Rating for Current Limiting Fuses Based on Transformer Primary Voltage and the National Electrical Code

VA	115V	120V	200V	208V	220V	230V	240V	277V	380V	400V	415V	440V	460V	480V	500V	550V	575V	600V
50	1.25	1.25	0.75	0.6	0.6	0.6	0.6	0.5	0.3	0.3	0.3	0.3	0.3	0.3	0.3	0.25	0.25	0.25
75	1.8	1.8	1.125	1	1	0.75	0.75	0.75	0.5	0.5	0.5	0.5	0.4	0.4	0.4	0.4	0.3	0.3
100	2.5	2.5	1.5	1.4	1.25	1.25	1.25	1	0.75	0.75	0.6	0.6	0.6	0.6	0.6	0.5	0.5	0.5
150	3.5	3.5	2.25	2	2	1.8	1.8	1.6	1.125	1.125	1	1	0.75	0.75	0.75	0.75	0.75	0.75
200	5	5	3	2.8	2.5	2.5	2.5	2	1.5	1.5	1.4	1.25	1.25	1.25	1.125	1	1	1
250	3.5	3.2	3.5	3.5	3.2	3.2	3	2.5	1.8	1.8	1.8	1.6	1.6	1.5	1.5	1.25	1.25	1.25
300	4	4	4.5	4	4	3.5	3.5	3.2	2.25	2.25	2	2	1.8	1.8	1.8	1.6	1.5	1.5
350	5	4.5	5	5	4.5	4.5	4	3.5	2.5	2.5	2.5	2.25	2.25	2	2	1.8	1.8	1.6
500	7	6.25	4	4	3.5	3.5	3.2	5	3.5	3.5	3.5	3.2	3.2	3	3	2.5	2.5	2.5
750	10	10	6.25	6	5.6	5	5	4.5	5.6	5.6	5	5	4.5	4.5	4.5	4	3.5	3.5
1000	12	12	8	8	7	7	6.25	6	4	4	4	3.5	3.5	3.2	3.2	5	5	5
1500	20	15	12	12	10	10	10	9	6.25	6.25	6	5.6	5	5	5	4.5	4	4
2000	20	20	12	12	10	12	12	12	8	8	8	7	7	6.25	6.25	6	5.6	5
3000	30	30	15	15	15	15	15	12	12	12	12	10	10	10	10	9	8	8

Primary Fuse Sizing Chart (When Primary and Secondary Protection is Used)

Maximum Amp Rating for Current Limiting Fuses Based on Transformer Primary Voltage and the National Electrical Code

VA	115V	120V	200V	208V	220V	230V	240V	277V	380V	400V	415V	440V	460V	480V	500V	550V	575V	600V
50	1	1	0.6	0.6	0.5	0.5	0.5	0.4	0.3	0.3	0.3	0.25	0.25	0.25	0.25	0.2	0.2	0.2
75	1.6	1.5	0.75	0.75	0.75	0.75	0.75	0.6	0.4	0.4	0.4	0.4	0.4	0.3	0.3	0.3	0.3	0.3
100	2	2	1.25	1.125	1.125	1	1	0.75	0.6	0.6	0.6	0.5	0.5	0.5	0.5	0.4	0.4	0.4
150	3.2	3	1.8	1.8	1.6	1.6	1.5	1.25	0.75	0.75	0.75	0.75	0.75	0.75	0.75	0.6	0.6	0.6
200	4	4	2.5	2.25	2	2	2	1.8	1.25	1.25	1.125	1.125	1	1	1	0.75	0.75	0.75
250	5	5	3	3	2.8	2.5	2.5	2.25	1.6	1.5	1.5	1.4	1.25	1.25	1.25	1.125	1	1
300	6.25	6.25	3.5	3.5	3.2	3.2	3	2.5	1.8	1.8	1.8	1.6	1.6	1.5	1.5	1.25	1.25	1.25
350	7	7	4	4	3.5	3.5	3.5	3	2.25	2	2	1.8	1.8	1.8	1.6	1.5	1.5	1.4
500	10	10	6.25	6	5.6	5	5	4.5	3.2	3	3	2.8	2.5	2.5	2.5	2.25	2	2
750	15	15	9	9	8	8	7	6.25	4.5	4.5	4.5	4	4	3.5	3.5	3.2	3.2	3
1000	20	20	12	12	10	10	10	9	6.25	6.25	6	5.6	5	5	5	4.5	4	4
1500	30	30	15	15	15	15	15	12	9	9	9	8	8	7	7	6.25	6.25	6.25
2000	40	40	25	20	20	20	20	15	12	12	12	10	10	10	10	9	8	8
3000	45	45	35	35	30	30	30	25	15	15	15	15	15	15	15	12	12	12

Secondary Fuse Sizing Chart

Maximum Amp Rating for Current Limiting Fuses Based on the National Electrical Code

VA	23V	24V	25V	85V	90V	95V	100V	110V	115V	120V	125V	130V	220V	230V	240V
50	3.5	3.2	3.2	0.75	0.75	0.75	0.75	0.75	0.6	0.6	0.6	0.6	0.3	0.3	0.3
75	5	5	5	1.4	1.25	1.25	1.25	1.125	1	1	1	0.75	0.5	0.5	0.5
100	7	6.25	6.25	1.8	1.8	1.6	1.6	1.5	1.4	1.25	1.25	1.25	0.75	0.6	0.6
150	10	10	10	2.8	2.5	2.5	2.5	2.25	2	2	2	1.8	1.125	1	1
200	12	12	12	3.5	3.5	3.5	3.2	3	2.8	2.5	2.5	2.5	1.5	1.4	1.25
250	15	15	15	4.5	4.5	4	4	3.5	3.5	3.2	3.2	3.2	1.8	1.8	1.6
300	20	20	20	5.6	5	5	5	4.5	4	4	4	3.5	2.25	2	2
350	20	20	20	6.25	6.25	6	5.6	5	5	4.5	4.5	4	2.5	2.5	2.25
500	—	—	—	9	9	8	8	7	7	6.25	6.25	6.25	3.5	3.5	3.2
750	—	—	—	12	12	12	12	10	10	10	10	9	5.6	5	5
1000	—	—	—	15	15	15	15	15	12	12	12	12	7	7	6.25
1500	—	—	—	25	25	25	25	20	20	20	20	15	10	10	10
2000	—	—	—	35	35	35	30	30	25	25	25	25	15	12	12
3000	—	—	—	—	—	—	—	45	40	40	40	35	20	20	20

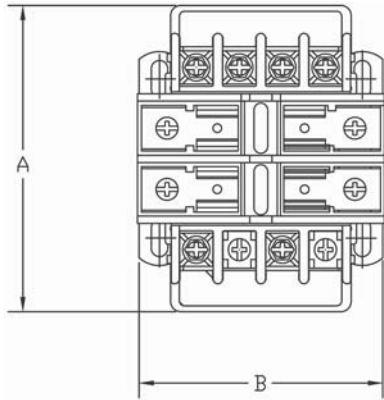

Transformer with 2 Primary Fuse Blocks and 0 or 1 Secondary Fuse Block/Clip (Top View)

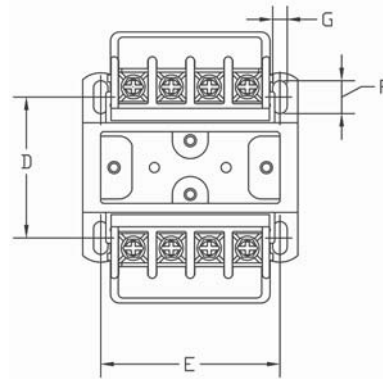

Transformer with 0 Primary Fuse Blocks and 0 or 1 Secondary Fuse Block/Clip (Top View)

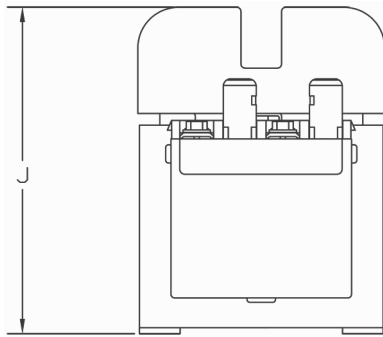

Transformer with 2 Primary Fuse Blocks and 1 Secondary Fuse Block/Clip (Side View)

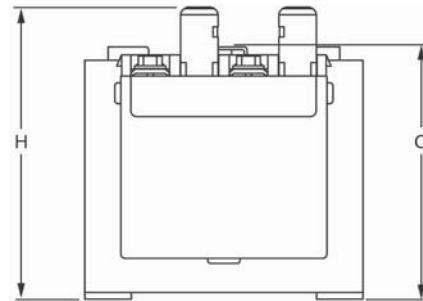

Transformer with 0 Primary Fuse Block and 1 Secondary Fuse Block/Clip (Side View)

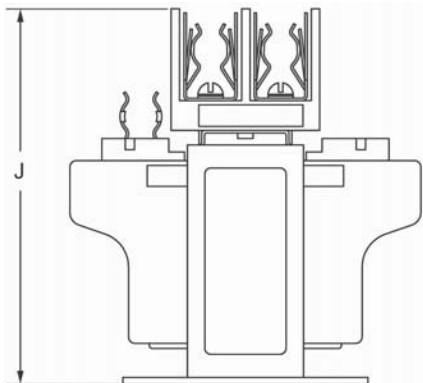

Transformer with 2 Primary Fuse Blocks and 1 Secondary Fuse Block/Clip (Side View)

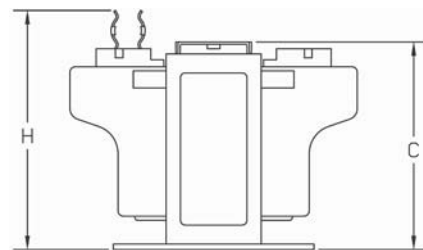

Transformer with 0 Primary Fuse Blocks and 1 Secondary Fuse Clip (Side View)

Control Power Transformers

Approximate Dimensions, Continued

Dimensions are shown in inches (millimeters). Dimensions are not intended to be used for manufacturing purposes.

VA	Cat. No.	A	B	C	D	E	F	G	H	J	Approx. Shipping Wt. lb (kg)
50	1497B-A1-M13-0-N	3-25/32 (96)	3 (76)	2-23/32 (69)	1-31/32 (50)	2-1/2 (64)	15/32 (12)	1/5 (5)	3-9/64 (80)	4-1/32 (102)	3 (1.4)
	1497B-A1-M16-0-N										
	1497B-A1-M17-0-N										
75	1497B-A2-M13-0-N	4-1/32 (102)	3 (76)	2-23/32 (69)	2-27/64 (61)	2-1/2 (64)	15/32 (12)	1/5 (5)	3-9/64 (80)	4-1/32 (102)	4 (1.8)
	1497B-A3-M11-0-N	4-1/16 (103)	3-3/4 (95)	3-23/64 (85)	2-13/32 (61)	3-1/8 (80)	15/32 (12)	1/5 (5)	3-49/64 (96)	4-21/32 (118)	5 (2.3)
100	1497B-A3-M12-0-N	4 (102)	3-3/8 (86)	3-3/64 (77)	2-27/64 (61)	2-13/16 (71)			3-15/32 (88)	4-23/64 (110)	
	1497B-A3-M13-0-N										
	1497B-A3-M16-0-N										
150	1497B-A3-M17-0-N										
	1497B-A4-M13-0-N	4-1/16 (103)	3-3/4 (95)	3-23/64 (85)	2-13/16 (71)	3-5/16 (80)	15/32 (12)	1/5 (5)	3-49/64 (96)	4-21/32 (118)	6 (2.7)
	1497B-A4-M16-0-N										
1497B-A4-M17-0-N											
200	1497B-A5-M11-0-N	4-3/8 (111)	4-1/2 (114)	3-31/32 (101)	2-5/8 (67)	3-3/4 (95)	15/32 (12)	1/5 (5)	4-2/5 (112)	5-9/32 (134)	10 (4.5)
	1497B-A5-M12-0-N										
	1497B-A5-M13-0-N										
250	1497B-A6-M13-0-N	4-3/8 (111)	4-1/2 (114)	3-31/32 (101)	2-53/64 (72)	3-3/4 (95)	15/32 (12)	1/5 (5)	4-2/5 (112)	5-9/32 (134)	10 (4.5)
	1497B-A6-M16-0-N										
	1497B-A6-M17-0-N										
300	1497B-A7-M11-0-N	4-3/4 (120)	4-1/2 (114)	3-31/32 (101)	3-3/16 (81)	3-3/4 (95)	15/32 (12)	1/5 (5)	4-2/5 (112)	5-9/32 (134)	12 (5.4)
	1497B-A7-M12-0-N										
	1497B-A7-M13-0-N										
500	1497B-A9-M11-0-N	6-7/64 (155)	5-1/4 (133)	4-5/8 (118)	3-7/8 (98)	4-3/8 (111)	1-1/16 (27)	5/16 (8)	—	5-15/16 (151)	18 (8.2)
	1497B-A9-M12-0-N										
	1497B-A9-M14-0-N										
	1497B-A9-M15-0-N										
750	1497B-A10-M12-0-N	7-39/64 (193)	5-1/4 (133)	4-5/8 (118)	5-7/8 (149)	4-3/8 (111)	1-1/16 (27)	5/16 (8)	—	5-15/16 (151)	28 (12.7)
	1497B-A10-M14-0-N										
	1497B-A10-M15-0-N										
1000	1497B-A11-M11-0-N	7-7/64 (181)	6-3/4 (171)	5-55/64 (149)	4-31/32 (126)	6-1/8 (155)	9/10 (23)	5/16 (8)	—	7-3/16 (183)	40 (18.1)
	1497B-A11-M12-0-N										
	1497B-A11-M14-0-N										
	1497B-A11-M15-0-N										41 (18.6)
1500	1497B-A12-M14-0-N	8-7/64 (206)	6-3/4 (171)	5-55/64 (149)	6-1/8 (155)	6-1/8 (155)	7/8 (22)	5/16 (8)	—	7-3/16 (183)	53 (24)
	1497B-A12-M15-0-N										61 (27.7)
2000	1497B-A13-M11-0-N	8-7/64 (206)	6-3/4 (171)	5-55/64 (149)	6-1/8 (155)	6-1/8 (155)	7/8 (22)	5/16 (8)	—	7-3/16 (183)	53 (24)
	1497B-A13-M12-0-N										
	1497B-A13-M14-0-N										
3000	1497B-A13-M15-0-N	8-7/64 (206)									
	1497B-A14-M11-0-N	8-9/16 (217)	9 (229)	7-41/64 (194)	5-13/16 (148)	7-1/2 (191)	9/10 (23)	7/16 (11)	—	8-61/64 (227)	78 (35.4)
	1497B-A14-M12-0-N										
	1497B-A14-M14-0-N										
1497B-A14-M15-0-N											

General Purpose Transformers

Overview/Catalog Number Explanation



Bulletin 1497D — General Purpose Transformers

Bulletin 1497D General Purpose Transformers are generally used for supplying appliance, lighting, motorized machine, and power loads from electrical distribution systems.

- 0.050...25.0 kVA (60 & 50/60 Hz)
- Indoor/outdoor non-ventilated enclosure
- Single phase
- Resin encapsulated
- Exceeds requirements of the Uniform Building Code (UBC) and California Code Title 24
- Copper windings provided for all transformers rated 2 kVA and below.
- Aluminum windings provided for all transformers rated 3 kVA and above.
- NEMA Type 3R rated enclosures

Table of Contents

Product Selection 8-56

Approximate Dimensions..... 8-60

Accessories..... 8-63

Standards Compliance

C22.2 No. 47 — M90
UL 506

Certifications

UL Listed (File No. E311296,
Guide No. XQNX)
CSA Certified (File No. LR1234)

Your order must include the cat. no. of the control circuit transformer selected.

Catalog Number Explanation

Bulletin 1497D General Purpose Transformers

1497D – A1 – M10 – 0 – N

a *b* *c* *d*

a

VA Rating	
Code	Description [VA]
A1	50
A2	75
A3	100
A4	150
A6	250
A9	500
A10	750
A11	1000
A12	1500
A13	2000
A14	3000
A15	5000
A16	7500
A17	10000
A18	15000
A20	25000

b

Primary and Secondary Voltage		
Code	Primary	Secondary
M10	240X480V	120/240V (60 Hz)
M11	600V	120/240V (60 Hz)
M14	240X480V	120/240V (50/60 Hz)
M20	208V	120/240V (60 Hz)
M21	480V	120/240V (60 Hz)
M22	480V	120/240V (50/60 Hz)
M23	600V	120/240V (50/60 Hz)
M24	480V	208V (60 Hz)

c

Fuse Block Options	
Code	Block Options
0	0 Primary, 0 Secondary

d

Factory Installed Options	
Code	Description
2	Two 5% taps below rated primary volts
22	2.5% taps: 2 above and 2 below rated primary volts
4	Four 2.5% taps below rated primary volts
N	No taps

Note: For complete list of valid transformer configurations, see page 8-56.

Bulletin 1497D
General Purpose Transformers
 Product Selection

208V Primary with No Taps

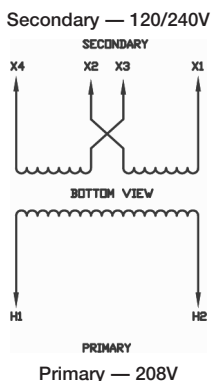

Winding	Voltage Accuracy [V]	Connect	Line
Primary	208	—	H1-H2
Secondary	240	X2-X3	H1-H4
	240/120*	X2-X3	X1-X3-X4
	120	X1X3-X2X4	X1-X4

* Three wire operation

Continuous kVA	Frequency [Hz]	Temp. Rise [°C (°F)]	Cat. No.
0.050	60	115 (239)	1497D-A1-M20-0-N
0.075			1497D-A2-M20-0-N
0.100			1497D-A3-M20-0-N
0.150			1497D-A4-M20-0-N
0.250			1497D-A6-M20-0-N
0.500			1497D-A9-M20-0-N
0.750			1497D-A10-M20-0-N
1.0			1497D-A11-M20-0-N
1.5			1497D-A12-M20-0-N
2.0			1497D-A13-M20-0-N
3.0			1497D-A14-M20-0-N
5.0			1497D-A15-M20-0-N
7.5			1497D-A16-M20-0-N
10.0			1497D-A17-M20-0-N
15.0			1497D-A18-M20-0-N
25.0			1497D-A20-M20-0-N

240x480V Primary with No Taps

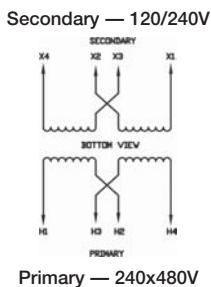

Winding	Voltage Accuracy [V]	Connect	Line
Primary	480	H2-H3	H1-H4
	240	H1H3-H2H4	H1-H4
Secondary	240	X2-X3	H1-H4
	240/120*	X2-X3	X1-X3-X4
	120	X1X3-X2X4	X1-X4

* Three wire operation

Continuous kVA	Frequency [Hz]	Temp. Rise [°C (°F)]	Cat. No.
0.050	60	115 (239)	1497D-A1-M10-0-N
	50/60		1497D-A1-M14-0-N
0.075	60		1497D-A2-M10-0-N
	50/60		1497D-A2-M14-0-N
0.100	60		1497D-A3-M10-0-N
	50/60		1497D-A3-M14-0-N
0.150	60		1497D-A4-M10-0-N
	50/60		1497D-A4-M14-0-N
0.250	60		1497D-A6-M10-0-N
	50/60		1497D-A6-M14-0-N
0.500	60		1497D-A9-M10-0-N
	50/60		1497D-A9-M14-0-N
0.750	60		1497D-A10-M10-0-N
	50/60		1497D-A10-M14-0-N
1.0	60		1497D-A11-M10-0-N
	50/60		1497D-A11-M14-0-N
1.5	60		1497D-A12-M10-0-N
	50/60		1497D-A12-M14-0-N
2.0	60		1497D-A13-M10-0-N
	50/60		1497D-A13-M14-0-N
3.0	60	1497D-A14-M10-0-N	
	50/60	1497D-A14-M14-0-N	
5.0	60	1497D-A15-M10-0-N	
	50/60	1497D-A15-M14-0-N	
7.5	60	1497D-A16-M10-0-N	
	50/60	1497D-A16-M14-0-N	
10.0	60	1497D-A17-M10-0-N	
	50/60	1497D-A17-M14-0-N	
15.0	60	1497D-A18-M10-0-N	
	50/60	1497D-A18-M14-0-N	
25.0	60	1497D-A20-M10-0-N	
	50/60	1497D-A20-M14-0-N	

480V Primary with No Taps

Secondary — 120/240V

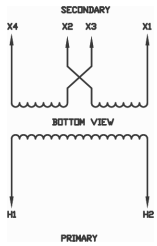

Primary — 480V

Winding	Voltage Accuracy [V]	Connect	Line
Primary	480	—	H1-H2
Secondary	240	X2-X3	H1-H4
	240/120*	X2-X3	X1-X3-X4
	120	X1X3-X2X4	X1-X4

Continuous kVA	Frequency [Hz]	Temp. Rise [°C (°F)]	Cat. No.
0.050	60	115 (239)	1497D-A1-M21-0-N
0.075			1497D-A2-M21-0-N
0.100			1497D-A3-M21-0-N
0.150			1497D-A4-M21-0-N
0.250			1497D-A6-M21-0-N
0.500			1497D-A9-M21-0-N
0.750			1497D-A10-M21-0-N
1.0			1497D-A11-M21-0-N
1.5			1497D-A12-M21-0-N
2.0			1497D-A13-M21-0-N
3.0	1497D-A14-M21-0-N		
5.0	50/60	115 (239)	1497D-A15-M22-0-N
7.5			1497D-A16-M22-0-N
10.0			1497D-A17-M22-0-N
15.0			1497D-A18-M22-0-N
25.0			1497D-A20-M22-0-N

Secondary — 208V

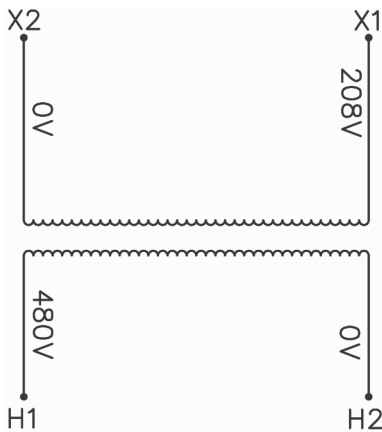

Primary — 480V

Continuous kVA	Frequency [Hz]	Temp. Rise [°C (°F)]	Cat. No.
0.050	60	115 (239)	1497D-A1-M24-0-N
0.075			1497D-A2-M24-0-N
0.100			1497D-A3-M24-0-N
0.150			1497D-A4-M24-0-N
0.250			1497D-A6-M24-0-N
0.500			1497D-A9-M24-0-N
0.750			1497D-A10-M24-0-N
1.0			1497D-A11-M24-0-N
1.5			1497D-A12-M24-0-N
2.0			1497D-A13-M24-0-N
3.0			1497D-A14-M24-0-N
5.0			1497D-A15-M24-0-N
7.5			1497D-A16-M24-0-N
10.0			1497D-A17-M24-0-N
15.0			1497D-A18-M24-0-N
25.0			1497D-A20-M24-0-N

480V Primary with Two 5% Taps Below Rated Primary Volts

Secondary — 120/240V

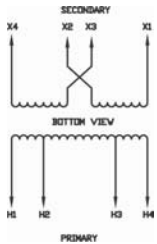

Primary — 480V

Winding	Voltage Accuracy [V]	Connect	Line
Primary	480	—	H1-H4
	456	—	H2-H4
	432	—	H2-H3
Secondary	240	X2-X3	H1-H4
	240/120*	X2-X3	X1-X3-X4
	120	X1X3-X2X4	X1-X4

Continuous kVA	Frequency [Hz]	Temp. Rise [°C (°F)]	Tap Quantity	Cat. No.
0.250	50/60	115 (239)	(2) 5% FCBN	1497D-A6-M22-0-2
0.500				1497D-A9-M22-0-2
0.750				1497D-A10-M22-0-2
1.0	60			1497D-A11-M21-0-2
	50/60			1497D-A11-M22-0-2
1.5	60			1497D-A12-M21-0-2
	50/60			1497D-A12-M22-0-2
2.0	60			1497D-A13-M21-0-2
	50/60			1497D-A13-M22-0-2
3.0	60			1497D-A14-M21-0-2
	50/60			1497D-A14-M22-0-2
5.0	60			1497D-A15-M21-0-2
7.5				1497D-A16-M21-0-2
10.0				1497D-A17-M21-0-2
15.0				1497D-A18-M21-0-2
25.0				1497D-A20-M21-0-2

* Three wire operation

Bulletin 1497D
General Purpose Transformers
 Product Selection, Continued

480V Primary with Two 2.5% Taps Above & Two 2.5% Below Rated Primary Volts

Secondary — 120/240V

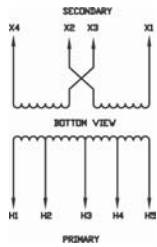

Primary — 480V

Winding	Voltage Accuracy [V]	Connect	Line
Primary	504	—	H1-H5
	492	—	H1-H4
	480	—	H1-H3
	468	—	H2-H4
	456	—	H2-H3
Secondary	240	X2-X3	H1-H4
	240/120*	X2-X3	X1-X3-X4
	120	X1X3-X2X4	X1-X4

Continuous kVA	Frequency [Hz]	Temp. Rise [°C (°F)]	Tap Quantity	Cat. No.
3.0	60	115 (239)	(2) 2.5% FCAN (2) 2.5% FCBN	1497D-A14-M21-0-22
5.0				1497D-A15-M21-0-22
7.5				1497D-A16-M21-0-22
10.0				1497D-A17-M21-0-22
15.0				1497D-A18-M21-0-22
25.0				1497D-A20-M21-0-22

600V Primary with No Taps

Secondary — 120/240V

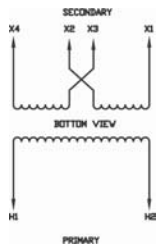

Primary — 600V

Winding	Voltage Accuracy [V]	Connect	Line
Primary	600	—	H1-H2
Secondary	240	X2-X3	H1-H4
	240/120*	X2-X3	X1-X3-X4
	120	X1X3-X2X4	X1-X4

* Three wire operation

Continuous kVA	Frequency [Hz]	Temp. Rise [°C (°F)]	Cat. No.
0.050	60	115 (239)	1497D-A1-M11-0-N
0.075			1497D-A2-M11-0-N
0.100	60		1497D-A3-M11-0-N
	50/60		1497D-A3-M23-0-N
0.150	60		1497D-A4-M11-0-N
0.250	60		1497D-A6-M11-0-N
	50/60		1497D-A6-M23-0-N
0.500	60		1497D-A9-M11-0-N
	50/60		1497D-A9-M23-0-N
0.750	60		1497D-A10-M11-0-N
	50/60		1497D-A10-M23-0-N
1.0	60		1497D-A11-M11-0-N
1.5			1497D-A12-M11-0-N
2.0			1497D-A13-M11-0-N
3.0		1497D-A14-M11-0-N	
5.0		1497D-A15-M11-0-N	
7.5		1497D-A16-M11-0-N	
10.0		1497D-A17-M11-0-N	
15.0		1497D-A18-M11-0-N	
25.0		1497D-A20-M11-0-N	

600V Primary with Two 5% Taps Below Rated Primary Volts

Secondary — 120/240V

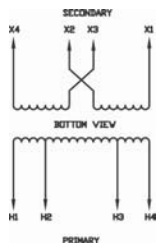

Primary — 600V

Winding	Voltage Accuracy [V]	Connect	Line
Primary	600	—	H1-H2
	570	—	H1-H3
	540	—	H2-H3
Secondary	240	X2-X3	H1-H4
	240/120*	X2-X3	X1-X3-X4
	120	X1X3-X2X4	X1-X4

Continuous kVA	Frequency [Hz]	Temp. Rise [°C (°F)]	Tap Quantity	Cat. No.
0.250	50/60	115 (239)	(2) 5% FCBN	1497D-A6-M23-0-2
0.500				1497D-A9-M23-0-2
1.0	60			1497D-A11-M11-0-2
	50/60			1497D-A11-M23-0-2
1.5	60			1497D-A12-M11-0-2
2.0	60			1497D-A13-M11-0-2
3.0	60			1497D-A14-M11-0-2
	50/60			1497D-A14-M23-0-2
5.0	60			1497D-A15-M11-0-2
7.5				1497D-A16-M11-0-2
10.0		1497D-A17-M11-0-2		

600V Primary with Four 2.5% Taps Below Rated Primary Volts

Secondary — 120/240V

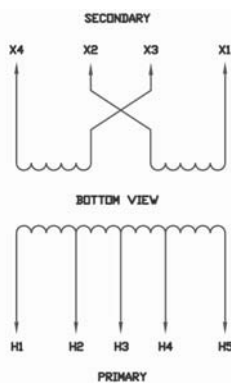

Primary — 600V

Winding	Voltage Accuracy [V]	Connect	Line
Primary	600	—	H1-H5
	585	—	H1-H4
	570	—	H1-H3
	555	—	H2-H4
	540	—	H2-H3
Secondary	240	X2-X3	X1-X4
	240/120*	X2-X3	X1-X3-X4
	120	X1X3-X2X4	X1-X4

Continuous kVA	Frequency [Hz]	Temp. Rise [°C (°F)]	Tap Quantity	Cat. No.
15.0	60	115 (239)	(4) 2.5% FCBN	1497D-A18-M11-0-4
25.0				1497D-A20-M11-0-4

* Three wire operation

General Purpose Transformers

Approximate Dimensions

Dimensions are shown in inches (millimeters). Dimensions are not intended to be used for manufacturing purposes.

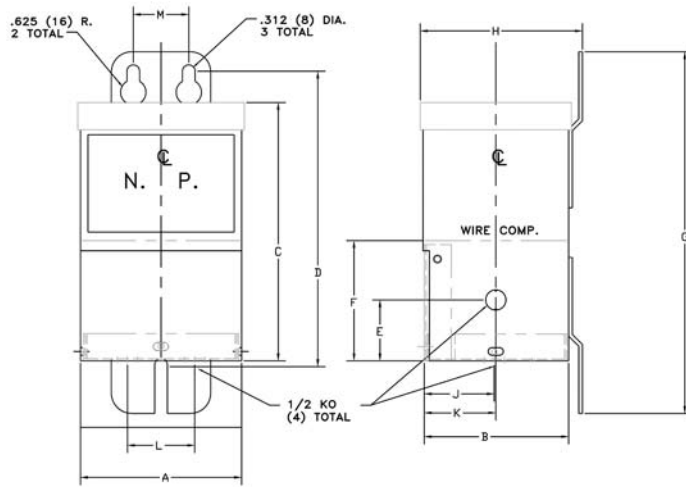

VA	A	B	C	D	E	F	G	H	J	K	L	M	Approximate Shipping Wt.
													lb (kg) Copper
50	3-31/32 (101)	3-9/16 (90)	6-23/64 (162)	7-17/64 (185)	1-1/2 (38)	2-61/64 (75)	8-29/32 (226)	4 (102)	1-47/64 (44)	1-49/64 (45)	1-2/3 (42)	1-3/8 (35)	8 (4)
100	3-31/32 (101)	3-9/16 (90)	6-23/64 (162)	7-17/64 (185)	1-1/2 (38)	2-61/64 (75)	8-29/32 (226)	4 (102)	1-47/64 (44)	1-49/64 (45)	1-2/3 (42)	1-3/8 (35)	8 (4)
150	3-31/32 (101)	3-9/16 (90)	6-23/64 (162)	7-17/64 (185)	1-1/2 (38)	2-61/64 (75)	8-29/32 (226)	4 (102)	1-47/64 (44)	1-49/64 (45)	1-2/3 (42)	1-3/8 (35)	8 (4)

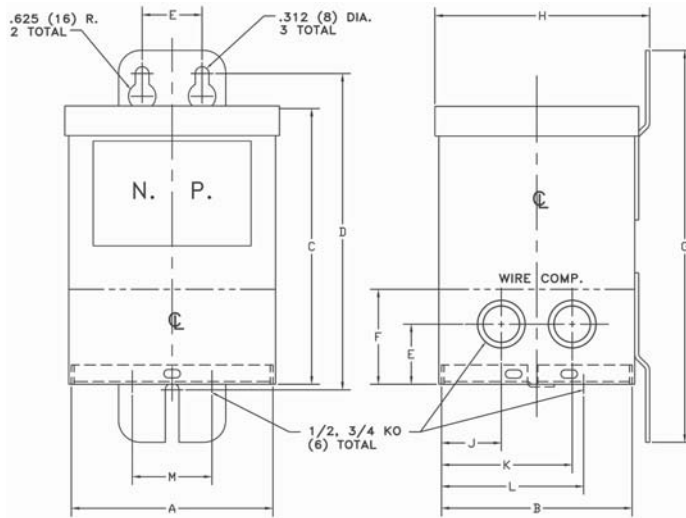

VA	A	B	C	D	E	F	G	H	J	K	L	M	Approximate Shipping Wt.
													lb (kg) Copper
250	4-39/64 (117)	10-3/8 (264)	6-5/16 (160)	7-1/4 (184)	1-3/8 (35)	2-11/64 (57)	8-31/32 (228)	4-1/16 (103)	15/16 (24)	2-9/16 (65)	2-33/64 (64)	1-53/64 (46)	15 (6)
500	4-39/64 (117)	4-23/64 (111)	6-5/16 (160)	7-1/4 (184)	1-3/8 (35)	2-11/64 (57)	8-31/32 (228)	4-29/32 (125)	1-3/8 (35)	3 (76)	3-3/8 (86)	1-53/64 (46)	16 (7)

8

Dimensions are shown in inches (millimeters). Dimensions are not intended to be used for manufacturing purposes.

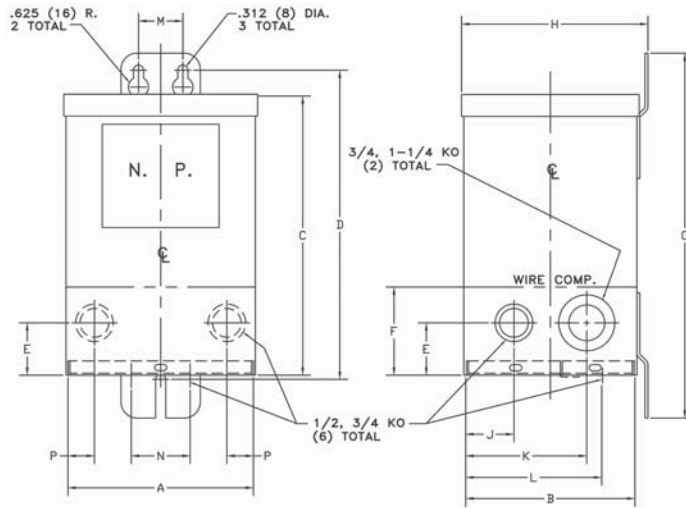

VA	A	B	C	D	E	F	G	H	J	K	L	M	N	P	Approximate Shipping Wt.
															lb (kg) Copper
750	5-47/64 (146)	5-15/64 (133)	8-5/8 (219)	9-35/64 (243)	1-5/8 (41)	2-47/64 (69)	11-9/32 (287)	5-3/4 (146)	1-1/2 (38)	3-3/4 (95)	4-1/4 (108)	1-3/8 (35)	1-53/64 (46)	7/8 (22)	24 (11)
1000	5-47/64 (146)	5-15/64 (133)	8-5/8 (219)	9-35/64 (243)	1-5/8 (41)	2-47/64 (69)	11-9/32 (287)	5-3/4 (146)	1-1/2 (38)	3-3/4 (95)	4-1/4 (108)	1-3/8 (35)	1-53/64 (46)	7/8 (22)	36 (16)
1500	6-1/10 (155)	6 (152)	10-3/4 (273)	11-49/64 (299)	1-3/4 (44)	3 (76)	13-13/32 (341)	6-33/64 (166)	1-7/8 (48)	4-1/8 (105)	4-53/64 (122)	1-3/8 (35)	1-53/64 (46)	1 (25)	50 (23)
2000	6-1/10 (155)	6 (152)	10-3/4 (273)	11-49/64 (299)	1-3/4 (44)	3 (76)	13-13/32 (341)	6-33/64 (166)	1-7/8 (48)	4-1/8 (105)	4-53/64 (122)	1-3/8 (35)	1-53/64 (46)	1 (25)	50 (23)

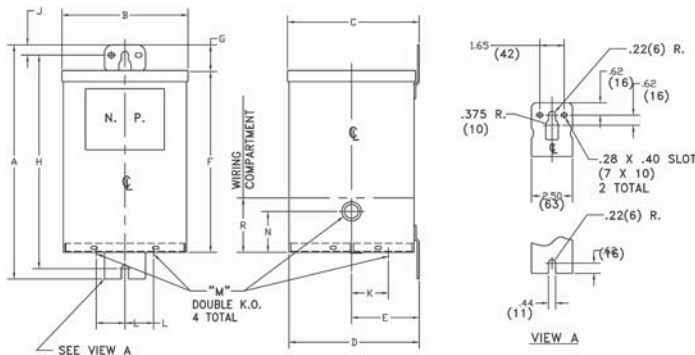

VA	A	B	C	D	E	F	G	H	J	K	L	M	N	R	Approximate Shipping Wt.
															lb (kg) Aluminum
3000	14-1/4 (362)	7-11/16 (195)	8 (203)	7-15/16 (202)	4-1/6 (103)	11-1/16 (281)	1-5/8 (41)	13 (330)	5/8 (18)	2-1/4 (57)	1-3/4 (44)	1/2, 3/4 (13, 19)	2-1/2 (64)	3-21/64 (84)	65 (30)

Bulletin 1497D
General Purpose Transformers
 Approximate Dimensions, Continued

Dimensions are shown in inches (millimeters). Dimensions are not intended to be used for manufacturing purposes.

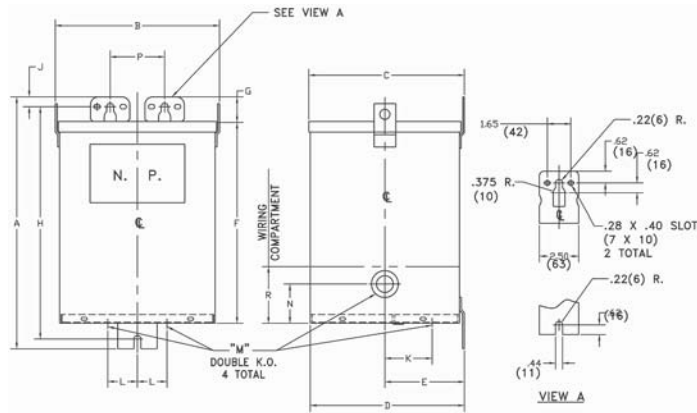

kVA	A	B	C	D	E	F	G	H	J	K	L	M	N	P	Q	R	Approximate Shipping Wt.	
																	lb (kg)	
																		Aluminum
5	16 (406)	10-3/8 (264)	9-57/64 (249)	9-4/5 (249)	5-1/6 (129)	12-53/64 (326)	1-5/8 (41)	14-3/4 (375)	5/8 (18)	3 (76)	1-7/8 (48)	3/4, 1-1/4 (19, 32)	2-1/2 (64)	3-15/32 (88)	—	3-39/64 (92)	113 (51)	
7.5	16 (406)	10-3/8 (264)	9-57/64 (249)	9-4/5 (249)	5-1/6 (129)	12-53/64 (326)	1-5/8 (41)	14-3/4 (375)	5/8 (18)	3 (76)	1-7/8 (48)	3/4, 1-1/4 (19, 32)	2-1/2 (64)	3-15/32 (88)	—	3-39/64 (92)	123 (56)	
10	19 (483)	13-3/8 (340)	10-33/64 (267)	10-15/32 (266)	5-7/6 (138)	15-53/64 (402)	1-5/8 (41)	17-3/4 (451)	5/8 (18)	3-3/8 (86)	1-7/8 (48)	3/4, 1-1/4 (19, 32)	2-1/2 (64)	3-15/32 (88)	1, 1-1/2 (25, 38)	3-3/4 (95)	193 (88)	
15	19 (483)	13-3/8 (340)	10-33/64 (267)	10-15/32 (266)	5-7/6 (138)	15-53/64 (402)	1-5/8 (41)	17-3/4 (451)	5/8 (18)	3-3/8 (86)	1-7/8 (48)	3/4, 1-1/4 (19, 32)	2-1/2 (64)	3-15/32 (88)	1, 1-1/2 (25, 38)	3-3/4 (95)	216 (98)	

8

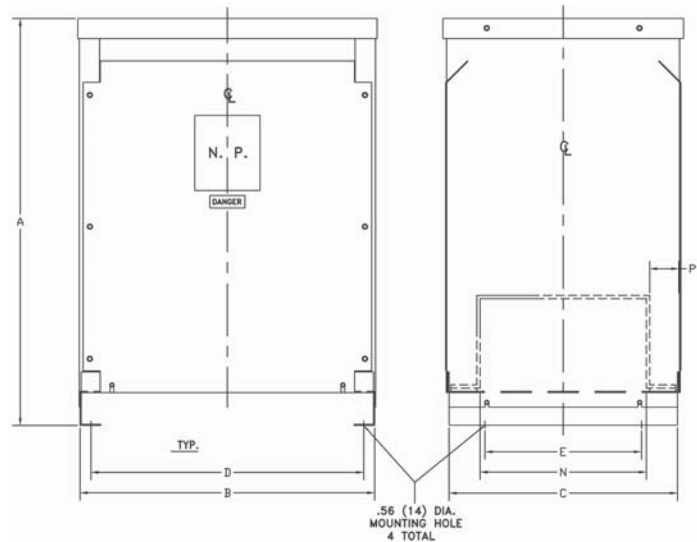

kVA	A	B	C	D	E	F	G	H	J	K	L	M	N	O	P	Approximate Shipping Wt.	
																lb (kg)	
																	Aluminum
25	31-1/4 (793)	22-19/32 (574)	17.5 (445)	20-29/32 (531)	12 (305)	2-17/32 (64)	3-17/64 (83)	7/8 (22)	2-7/8 (49)	10-15/16 (277)	8-5/16 (211)	7-5/32 (182)	12-3/4 (324)	2-13/16 (71)	2-1/4 (57)	212 (96)	

Fuse Block Kits — For Use when Fuse Block is Not Integrated with the Transformer



Cat. No. 1491-R165
1-Pole Fuse Block



Cat. No. 1491-R167
2-Pole Fuse Block



Cat. No. 1491-R171
3-Pole Fuse Block



Cat. No. 1491-R169
3-Pole Fuse Block



Cat. No. 1491-R150
Fuse Cover without Fuse

These control circuit fusing kits are intended to be used for control circuit transformer protection and protection of control circuits capable of delivering no more than 200 000 RMS symmetrical amps, 600V maximum.

Description*	Cat. No.
Fuse cover — per pole	1491-R150
One-pole kit — panel-mounted (midget fuse)*	1491-R165
Two-pole kit — panel-mounted (two Class CC fuses)*	1491-R162
Two-pole kit — panel-mounted (two midget fuses)*	1491-R167
Three-pole kit — panel-mounted (one midget fuse/two Class CC fuses)*	1491-R169
Three-pole kit — panel-mounted (three Class CC fuses)*	1491-R171
Single-pole kit — Bulletin 500 line controller mounted (Class CC fuses)‡	599-FR04
One-pole kit — panel-mounted (31...60 A Class J fuse)	1491-R173
One-pole kit — panel-mounted (61...100 A Class J fuse)	1491-R175

* For control circuit transformers with a 350VA or larger rating, it is recommended that Bussmann Type FNQ-R, Ferraz-Shawmut Type ATDR, Littelfuse Type KLDR time delay fuses, or equivalent be used for primary fusing.

* These kits use only Class CC or Midget fuses (rated 0.5...30 A) such as those offered by the following manufacturers:

- Bussmann KTK-R
- Ferraz-Shawmut ATM R
- Littelfuse KLK

‡ Cat. No. 599-FR04 is rated for 6 A fuse maximum. Controller mounting applies to size 0...5 devices only.